

Adaptation of a Dual-Frequency 104/140 GHz Gyrotron for Operation at 175 GHz

Stephen Cauffman^{1,*}, Monica Blank¹, Philipp Borchard¹, and Kevin Felch¹

¹Communications and Power Industries, 607 Hansen Way, Palo Alto, California, 94304, USA

Abstract. A dual-frequency gyrotron capable of operation in the $TE_{28,7}$ cavity interaction mode at 140 GHz, or in the $TE_{22,5}$ mode at 104 GHz, has been developed for use in electron cyclotron heating in the W7-X stellarator at IPP Greifswald. The gyrotron incorporates an internal converter design that has been numerically optimized to convert either of the two operating modes into a high-quality Gaussian output beam. During short-pulse factory testing, the gyrotron produced 900 kW at 140 GHz, and 520 kW at 104 GHz. After delivery to IPP, the gyrotron was conditioned to long-pulse operation at 140 GHz, demonstrating 30-minute pulses at several power levels up to 811 kW, and producing ten consecutive ten-minute pulses at 811 kW as well. After long-pulse capabilities were demonstrated at 140 GHz, IPP requested an analysis of the feasibility of operating the gyrotron (without internal modification) in an additional mode with a frequency near 175 GHz. Several potential interaction modes were evaluated to determine the required operating parameters for excitation of these modes, and to assess the expected interaction efficiency, output power, internal diffraction losses, and output beam quality. The most promising modes appear to be the $TE_{33,9}$ (173 GHz) and the $TE_{34,9}$ (176 GHz), which should generate 400-500 kW of RF in a suitable magnet capable of producing the necessary 7.1 T field required for operation at these higher frequencies. Because the existing gyrotron's internal converter was not optimized for these modes, however, internal losses are expected to be higher than usual (up to 7%), and the output beam pattern will require external phase-correction in order to produce a Gaussian beam. A feasibility analysis for such external phase correction has been performed, demonstrating that a high-quality beam can be recovered using numerically synthesized external phase-correcting mirror surfaces.

1 Introduction

Gyrotrons are vacuum electron devices that make use of the cyclotron resonance maser instability to convert DC power into millimetre-wave radiation. An annular beam of helically propagating electrons travels along the flux lines produced by a solenoid magnet, and the electron beam's rotational energy (the energy of motion transverse to the magnetic field) is used to excite a resonant transverse electric eigenmode in a cylindrical interaction cavity. Operation at high average power (~1 MW) has been demonstrated in numerous gyrotrons at frequencies up to 170 GHz, using highly-overmoded interaction circuits. (For a comprehensive summary of the current state-of-the-art, see Reference 1.) The primary applications for such megawatt-class gyrotron oscillators are fusion plasma heating, current-drive, and plasma instability suppression. Localized electron cyclotron heating of fusion plasmas makes use of millimetre-wave beams injected with a frequency matching the electron cyclotron frequency for the magnetic field at the desired heating location in the plasma. While many gyrotrons are designed for operation at one specific frequency, some designs are

optimized to support operation in several different eigenmodes.

Communications & Power Industries (CPI) has designed and fabricated a 2-frequency gyrotron capable of operation at either 140 GHz or 104 GHz, for use in plasma heating in the W7-X fusion stellarator at IPP Greifswald. Although the gyrotron was originally intended to support operation at these two frequencies, in order to allow for compatibility with stellarator plasmas generated at less than full field, the need for operation at the lower frequency did not materialize. Preliminary factory tests of the gyrotron confirmed proper operation at both frequencies, but subsequent tests focused solely on 140 GHz operation. After testing of the gyrotron, IPP requested an analysis of the feasibility of operating the gyrotron at a higher frequency near 175 GHz, for possible use in plasma diagnostics. CPI performed analyses to determine possible modes of operation, and to evaluate the expected performance in those modes.

This paper summarizes (a) the design of the gyrotron, (b) the demonstrated operation of the gyrotron during factory testing and during acceptance testing at the customer site, and (c) the results of the feasibility study evaluating the possibility of operation at ~175 GHz.

* Corresponding author: steve.cauffman@cpii.com

2 Gyrotron Design

Figure 1 shows the gyrotron, installed after delivery to IPP Greifswald. A schematic layout of the gyrotron is shown in Figure 2. The gyrotron employs a single-anode electron gun with a thermionic cathode, to produce an annular electron beam. The gyrotron is designed for compatibility with the magnetic field produced by a superconducting magnet which governs the propagation of the electron beam from the electron gun, through the interaction circuit, and into the collector, which dissipates the power remaining in the electron beam after the extraction of RF power. The collector voltage is depressed, relative to the interaction circuit, to improve overall device efficiency and reduce thermal loads. An internal converter consisting of a tapered, dimpled-wall launcher and a set of three phase-correcting and beam steering mirrors transforms the interaction mode into a freely propagating Gaussian TEM₀₀ beam, which exits the gyrotron in the radial direction, through a vacuum window made of CVD diamond.



Fig. 1. The VGT-8141A gyrotron, installed at the customer site.

The gyrotron design is an adaptation of a previously demonstrated single-frequency design, which was developed to produce millimetre-wave radiation at 140 GHz, via excitation of the TE_{28,7} mode [2]. To reduce technical risk, the pre-existing single-frequency 140 GHz gyrotron design was minimally modified, in order to allow for operation at 104 GHz as well. The electron gun, the interaction circuit, the output window, and the collector were kept unchanged. A slight modification to the beam tunnel, near the entrance to the interaction circuit, was necessary to ensure adequate electron beam clearance when operating at the slightly larger beam size required for excitation of the 104 GHz TE_{22,5} mode. The modified internal converter was numerically optimized to maximize Gaussian content at both operating frequencies, while ensuring low diffraction losses inside the gyrotron, keeping the positions of the launcher and mirrors similar to those in the original design, and minimizing the angular divergence of the two possible output beams.

The gun and cavity were optimized for performance at the 140 GHz operating frequency, employing the TE_{28,7} interaction mode, with simulations indicating that an 80 kV accelerating voltage and a beam current of 40 A should yield over 900 kW of output power, for a peak magnetic field value of 5.54 T. Simulations indicated that the 104 GHz TE_{22,5} mode could be excited with reasonable efficiency, yielding an expected output power over 500 kW, by reducing the magnetic field to 3.98 T, modifying the relative currents in the superconducting magnet coils to yield the required beam radius for excitation of the TE_{22,5} mode in the interaction circuit, and reducing the accelerating voltage to 60 kV to yield a suitable beam pitch factor (v_{\perp}/v_{\parallel}) for optimal output power.

The simulated performance of the dual-frequency internal converter is shown in Figure 3. The launcher converts either operating mode into a high-quality Gaussian beam, which is further shaped by numerically synthesized mirrors, which direct the beam to the output window. The two beams have slightly different sizes and waist positions, but are well centered on the window aperture, and have a differential angular divergence of less than 1.5 degrees.

3 Gyrotron Test Results

The nominal operating conditions and demonstrated performance of the dual-frequency gyrotron are summarized in Table 1. Factory testing was limited by the capabilities of the test set, which can operate at full beam voltage and current for short pulses (5 ms), or at beam currents up to 25A for longer pulses. Furthermore, although tests were performed to confirm operation at both frequencies, the tests at 104 GHz were limited in scope, because at the time of testing, the customer no longer anticipated a need for operation at the lower frequency. Conditioning of the gyrotron to full power and pulse length at 140 GHz was performed after delivery of the gyrotron to the customer site.

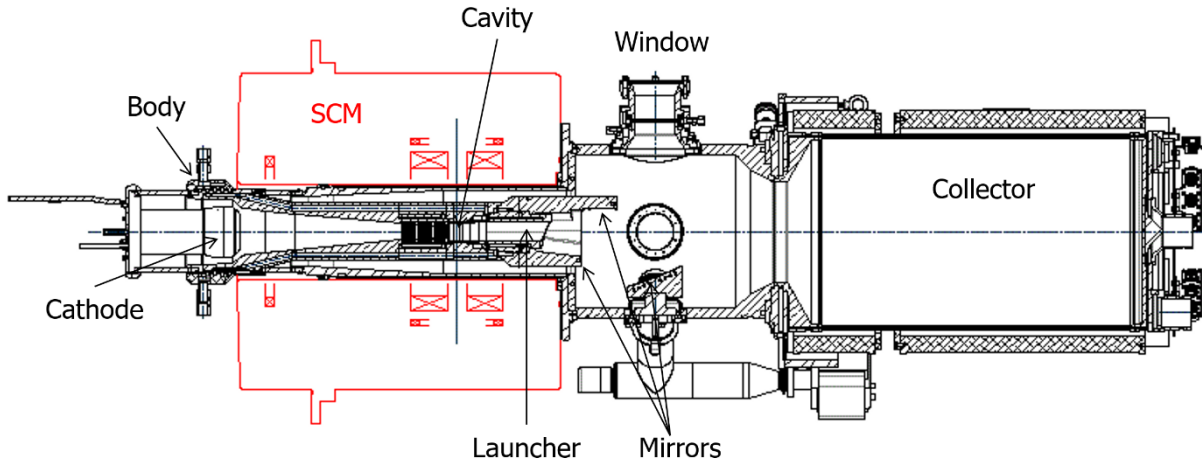

Fig. 2. A schematic of the VGT-8141A gyrotron.

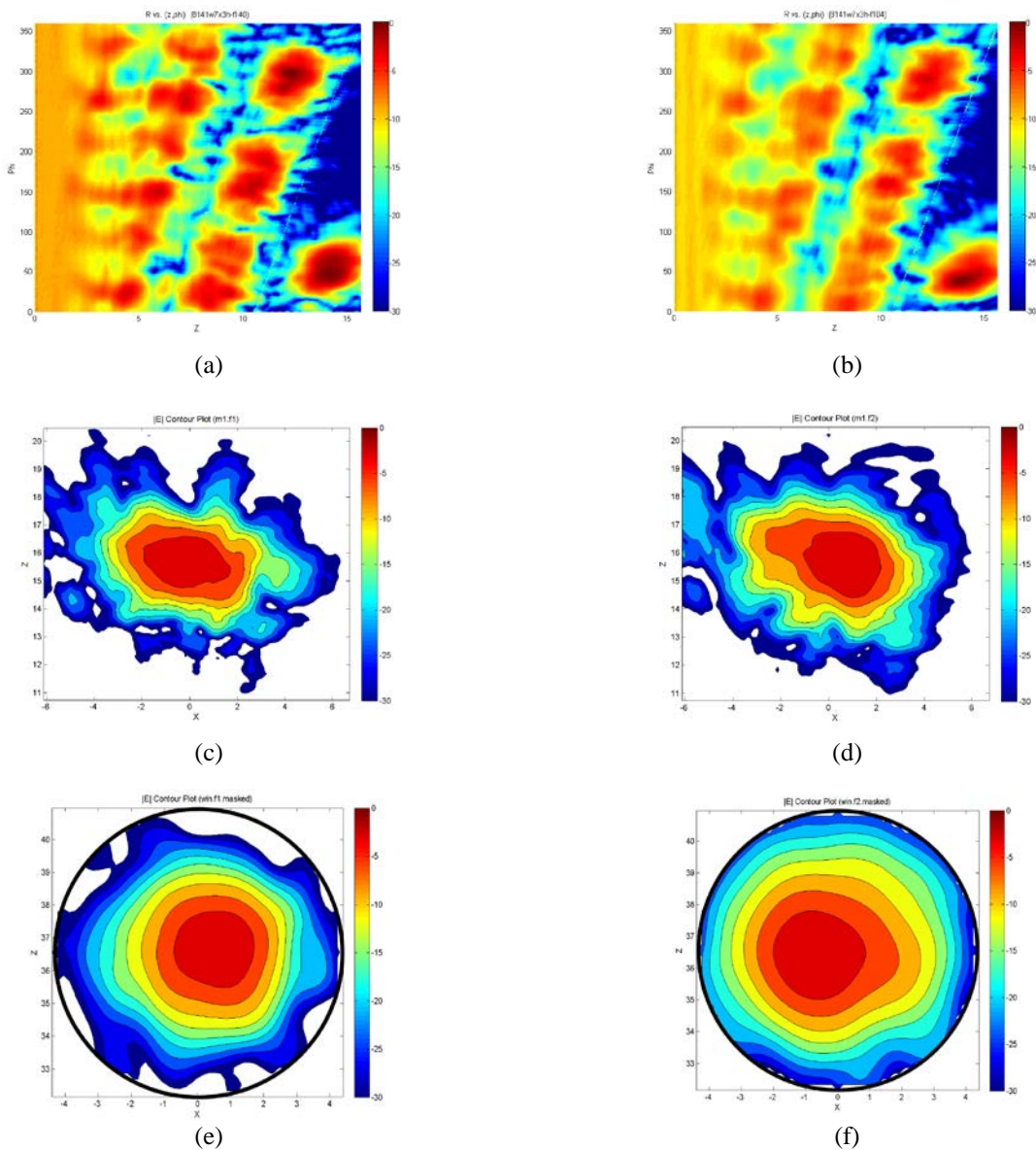

Fig. 3. Internal converter performance in the 140 GHz and 104 GHz operating modes. (a) Launcher wall fields for 140 GHz $TE_{28,7}$. (b) Launcher wall fields for 104 GHz $TE_{22,5}$. (c) Fields on Mirror 1 at 140 GHz. (d) Fields on Mirror 1 at 104 GHz. (e) Fields on Output Window at 140 GHz. (f) Fields on Output Window at 104 GHz. Color scales are dB. Linear dimensions are cm. Angular dimensions are degrees.

* Corresponding author: steve.cauffman@cpii.com

Table 1. Gyrotron Test Results.

Freq (GHz):	140		104	
Mode	TE _{28,7}		TE _{22,5}	
Pulse Len	20 ms	30 min	5 ms	100 ms
Acc. Voltage (kV)	84.4	84.3	60	60
Dep. Voltage (kV)	23.4	23.3	15	15
Beam Current (A)	46	39	40	25
Output Power (kW)	900	811	520	300
Test Location	IPP	IPP	CPI*	CPI**

Notes: *No 104 GHz tests at IPP. **No CW tests at 104 GHz.
 Demonstrated: 10 consecutive 10-minute pulses at 811 kW, no faults.
 30-minute pulses at 300 kW, 500 kW, 811 kW.

The gyrotron demonstrated 30-minute pulses at several power levels up to 811 kW and produced ten consecutive 10-minute pulses at 811 kW during final acceptance testing. Short-pulse testing yielded power levels over 900 kW, but stable operation for longer pulses was obtained by lowering the power level by about 10%.

4 Feasibility of 175 GHz Operation

After final testing of the 104/140 GHz gyrotron, IPP requested an analysis of the feasibility of operation at a higher frequency near 175 GHz (a value chosen, in part, to ensure compatibility with the existing gyrotron’s single-disc output window thickness, which should be an integral number of half-wavelengths thick, to minimize reflection). CPI performed feasibility analyses to determine whether higher-frequency modes could be excited with reasonable efficiency, and to evaluate the quality of the generated output beam under such conditions.

The first challenge for operation at higher frequency is the need for a higher magnetic field in the interaction region. The magnet for the existing system is not capable of operation at the required ~7 T. However, an

existing magnet design (model VYW-8170) for a similarly sized 170 GHz gyrotron (model VGT-8170) was found to be capable of generating the necessary field, and was also confirmed to be geometrically compatible with the VGT-8141A gyrotron, with slight modification to external mounting hardware.

Electron gun and cavity interaction simulations for the existing VGT-8141A gyrotron geometry were performed using the magnetic fields produced by the VGT-8170 magnet, to assess expected performance if the gyrotron were to be installed in the higher-field magnet. Several candidate modes in the frequency range of interest were identified and found to be capable of excitation in the existing gyrotron. The most promising candidates included the TE_{31,10} (176.6 GHz), the TE_{33,9} (173.0 GHz), and the TE_{34,9} (176.0 GHz). Optimal operating parameters for these modes were found by varying the magnet coil currents and accelerating voltage, while assuming a maximum beam current of 40A. These modes and frequencies were then used as inputs to simulations of the internal converter system, to evaluate the expected internal diffraction losses and the output beam quality if the gyrotron were to be operated in these modes. A summary of the simulated performance in these modes is provided in Table 2.

The internal losses for the TE_{31,10} were found to be too high (~20%) for long-pulse operation. The internal losses for the TE_{33,9} and TE_{34,9} are somewhat high (6-7%), but within the capabilities of the gyrotron’s internal RF-absorbing water-cooled loads. The output beam quality for each candidate mode near 175 GHz is extremely poor. The dimpled-wall launcher design that was optimized for two specific modes at 140 GHz and 104 GHz employs a complex pattern of radial variations to yield excellent beam quality with a very short launcher length (about 7 helical RF bounces). For the expected input modes at 104 GHz and 140 GHz, these wall perturbations yield a mixture of modes that results in a high-quality Gaussian beam, but when the launcher is operated in other modes, these perturbations yield an undesirable mode mixture resulting in poor output beam quality. Although it would be possible to design a longer launcher with better performance over a wider range of modes using more gradual evolution of the mode mixture, this was not one of the original design criteria for the VGT-8141A.

Table 2. Simulated performance of the VGT-8141A gun, cavity, and internal converter.

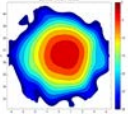
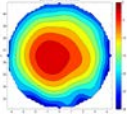
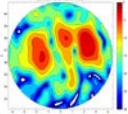
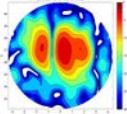
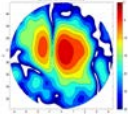
Frequency (GHz)	140	104	175.6	173.0	176.0
Mode	TE _{28,7}	TE _{22,5}	TE _{31,10}	TE _{33,9}	TE _{34,9}
B ₀ (T)	5.54	3.98	6.76	6.96	7.10
Voltage (kV)	80	60	62	85	85
Current (A)	40	40	40	40	40
P _{cavity} (kW) [MAGY]	975	727	678	799	619
Diffraction Loss (%)	1.1%	2.2%	19.6%	6.7%	6.3%
Field Pattern at Window					

* Corresponding author: steve.cauffman@cpil.com

Although not as elegant as having a high-quality beam exiting the gyrotron window, external phase-correcting mirrors can be synthesized to correct the output beam pattern, converting it back into a useable high-quality Gaussian beam. To establish the feasibility of this approach, synthesized mirrors were designed to convert the predicted poor-quality 176 GHz output beam into the desired Gaussian beam. Mirror positions were chosen based on the layout of IPP's external mirror system for directing and refocussing the output beam. The synthesized surfaces for the first two external mirrors yield a 98% match to the desired Gaussian beam at the transmission system's polarizer. The required sizes of the mirrors may be slightly larger than the existing layout allows for, however, so an adjustment of the mirror positions, by a few cm, may be necessary to ensure adequate clearance. Figure 4 shows the modelled layout of the external mirror system and the resultant RF beam pattern.

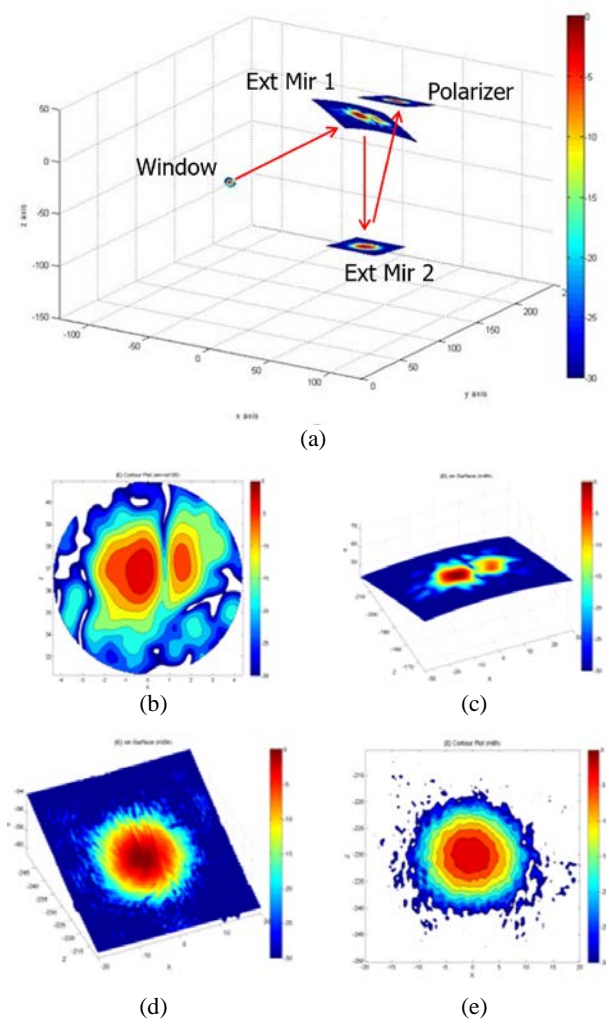

Fig. 4. External phase correction of 176 GHz radiation pattern using numerically synthesized mirror surfaces improves Gaussian beam coupling from 24% to 98%. Shown above: (a) Simulation geometry; (b) Field pattern at output window; (c) Field pattern at external mirror 1; (d) Field pattern at external mirror 2; (e) Field pattern at polarizer plane.

5 Summary

The VGT-8141A is a dual-frequency gyrotron capable of operation at either 140 GHz or 104 GHz. It has demonstrated short pulse operation at both frequencies (yielding over 900 kW at 140 GHz and over 500 kW at 104 GHz), and has demonstrated the ability to operate reliably at pulse lengths up to 30 minutes, for power levels up to 811 kW at 140 GHz.

The VGT-8141A gyrotron design is an adaptation of a previously demonstrated single-frequency gyrotron (the 140 GHz VGT-8141), with an internal converter that was re-optimized to support operation at 104 GHz while still producing a high-quality output beam.

Although the gyrotron was not designed for operation in other modes at other frequencies, it could be operated in either the 173 GHz $TE_{33,9}$ mode or the 176 GHz $TE_{34,9}$ mode, provided that a compatible 7.1 T superconducting magnet is available. Operation in such modes will yield higher internal RF losses (6-7%), and will result in a poor-quality output beam which will require external correction using synthesized mirror surfaces to convert the output radiation pattern into a TEM_{00} Gaussian beam.

References

1. M. Thumm, "State-of-the-Art of High Power Gyro-Devices and Free Electron Masers," KIT Scientific Reports 7750, Update 2017, DOI: 10.5445/KSP/1000081551.
2. M. Blank, P. Borchard, S. Cauffman, K. Felch, "Development and Demonstration of a 900 kW, 140 GHz gyrotron," 2015 IEEE International Vacuum Electronics Conference (IVEC), Beijing, 2015.

* Corresponding author: steve.cauffman@cpii.com