

Current status of ECE system on EAST tokamak

Hailin Zhao^{1,*}, Ang Ti^{1,**}, Tianfu Zhou¹, Zeying Zhu¹, Yong Liu¹, Bili Ling¹, Qing Zang¹, Juan Huang¹, and Xianzu Gong¹

¹Institute of Plasma Physics, Chinese Academy of Sciences, Hefei 230031, China

Abstract. The electron cyclotron emission (ECE) diagnostic on the experimental advanced superconducting tokamak (EAST) has had a major upgrade since 2020, when EAST heating system also went through a significant upgrade, including one NBI system changed from counter-current to co-current (moving from port F to port D), and the antenna and the installation port of LHW and ICRF system have also been changed. The quasi-optical (QO) antenna of P port ECE system has been redesigned, the main purpose of which is to add one oblique ECE view. The angle with respect to perpendicular to the magnetic field is about 10° , which will facilitate measurement of the electron velocity distribution altered by LHW system. The ellipsoidal mirror has also been moved close to the plasma, about 70 cm away from the plasma center, and the poloidal beam waist radius in the plasma has been optimised to be less than 3 cm. The CECE system has also been moved from port G to port C. The frequency coverage of the CECE system has been upgraded to 104-132 GHz by adding one radio frequency (RF) module. Also in the intermediate frequency (IF) module, 8 narrow-band filters have been added to improve the spacial coverage of the system. On port F, a new superheterodyne radiometer with narrow-band filters in IF module has been installed. It consists of eight channels, the radial coverage is about 8 cm, the main purpose of this new system is to study the fine structure of magnetic island.

1 Introduction

The electron cyclotron emission (ECE) diagnostic has been widely used in tokamak research since the 1960s[1]. It can provide important information on the time evolution of the electron temperature profile ($T_e(r)$), magneto-hydrodynamic (MHD) fluctuation spectra, non-thermal electron behavior and the ECE radiated power loss.

EAST[2] is a fully superconducting tokamak with a non-circular cross-section, The toroidal field can be as high as 2.6 T, the major radius $R = 1.85$ m, the minor radius $a = 0.45$ m. EAST tokamak has made an important advance by achieving stable 1056-second steady-state high-temperature plasma operation, setting a record for long-pulse operation in 2021[3].

The ECE diagnostic set has been developed on EAST tokamak for more than 10 years, and includes a conventional ECE system and a correlation ECE (CECE) system.

This paper is organized as follows: In section 2, the heating upgrade on EAST tokamak is introduced. The ECE system front end optical system upgrade is shown in section 3. The CECE upgrade is shown in section 4, a new high resolution ECE system is presented in section 5, and a summary is given in section 6.

2 EAST heating upgrade

In order to support the planned physical research on EAST, the auxiliary heating system was upgraded in 2020. The heating system includes neutral beam injection (NBI)[4], lower hybrid wave (LHW)[5] heating and current drive, ion cyclotron range-of frequency (ICRF)[6] heating and electron cyclotron heating (ECH)[7]. A high-power NBI system consisting of two injectors was employed on EAST for plasma heating and current drive. The designed deuterium beam energy is 50–80 keV, beam power is 2–4 MW, and the beam duration is 10–100 s. Each beamline is equipped with two hot cathode ion sources and can be

operated individually. The NBI-2 was shifted from port F to port D in 2020, and meanwhile, its injection direction was changed from counter-injection to co-injection. Furthermore, the high power ion source was optimized with better feedback control for stable long pulse beam. The LHW system includes two frequency system, 2.45 GHz and 4.6 GHz. The 2.45 GHz LHW system has a new PAM antenna and was moved from port N to port B. The total power of LHW system is about 6 MW. There were two fast wave heating antennas which are assembled at port I and port B on EAST. In 2020 the antenna at port B was moved from port B to port N, to decrease the effect of perturbation of ICRF on LHW systems. Before the change, when ICRF is turned on, the LHW system coupling is degraded, and the power absorbed by the plasma is also decreased. There are four units of EC systems (No. 1– No. 4), each of which has one gyrotron with a frequency of 140 GHz. An additional two gyrotrons system which have low frequency for low toroidal field is under development. Now the total ECH power can approach 2 MW.

3 ECE system front end optical system upgrade

The ECE system of EAST has been running for about 10 years. It includes a heterodyne system and a michelson interferometer system. The heterodyne system can measure the electron temperature with high spatial and temporal resolution, 2 cm and $2.5 \mu\text{s}$ respectively. Presently there are 56 channels, with frequency range 97 - 167 GHz. The michelson interferometer system was borrowed from JET, and the frequency range covers 80 - 500 GHz, while the temporal resolution is about 30 ms.

In 2020, taking advantage of the EAST tokamak upgrade, the front end optics of the ECE system in port P was upgraded. The most important change is the adding of a second quasi-optical system, making two, as shown in figure 1. One is for conventional ECE systems, another is for oblique ECE measurement. The angle with respect to perpendicular to the magnetic field is about 10° . It will

*e-mail: zhaohailin@ipp.ac.cn

**e-mail: ang@ipp.ac.cn

be used for future studies of high-energy electron distributions generated by LHW system. The beam spot size in the plasma region is less than 25 mm, and the poloidal resolution is improved compared to the old quasi-optical system, which was farther away from the plasma. The ellipsoidal mirror has also been moved closer to the plasma, about 70 cm away from the plasma center, and the poloidal beam waist radius in the plasma has been optimised to be less than 3 cm. After several experiment campaigns, which include wall cleaning, such as lithium coating, silication and so on, the ECE signal intensity is unchanged, this gives confidence to the use of stainless steel mirror as ECE first mirror in future fusion devices such as ITER.

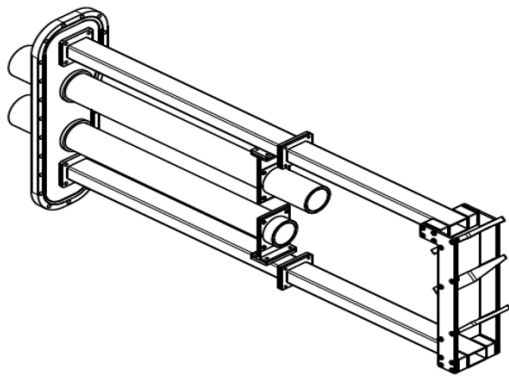

Figure 1. Two quasi-optical system for ECE front end

The ECE transmission waveguide is more than 40 meters in length. The direction of the waveguide was also rearranged due to conflict with the water cooling system. One more miter bend was added; the measured transmission loss for 81 to 110 GHz is shown in table 1. The measurement setup used one six-octave frequency to the 13.5 to 18.3 GHz local oscillator (LO), and one horn antenna as a source in the tokamak chamber, with another horn antenna connected to the power meter to measure the transmission waveguide attenuation for different dot frequencies. It can be seen that the attenuation of the 40 meters transmission waveguide for most frequencies is about 10 dB, with some frequencies reaching 14 dB. This roughly factor 10 attenuation of the input power to the transmission line is a significant reduction of signal to the ECE heterodyne receiver. The dominant loss source is believed to be the miter bends so the addition of another one has a deleterious effect. The lesson for future fusion devices such as ITER is to minimize the number of miter bends in transmission lines to keep losses small.

After the front end quasi-optical upgrade and the transmission waveguide direction rearranged, now the ECE signal is smaller than the time before the upgrade. An additional cause of power loss is a reduction of the size of the mirror in the front-end quasi-optical unit. The diameter of the mirror was reduced from 15 cm to 11 cm, thus reducing the surface area by about half. This combined with the extra miter bend loss has the result that the absolute intensity calibration is no longer possible. The voltage difference of

Table 1. The attenuation of the 40 meters transmission waveguide for different frequencies

frequency (GHz)	attenuation (dB)
81	-11.4
82	-10
83	-11.8
84	-7
85	-9.3
85	-9.3
86	-8.3
87	-7
88	-10.6
89	-10.5
90	-9
91	-9
92	-10
93	-11.7
94	-12
95	-11.2
96	-10.5
97	-11.1
98	-12.3
99	-11.5
100	-9.8
101	-12
102	-11.3
103	-11
104	-11.1
105	-14
106	-13.8
107	-12.5
108	-12.6
109	-10.4
110	-13.6

the output signal with a chopper as a reference is too small when using hot source inside the tokamak.

The upgrade of the ECE system in Port P cannot be considered a complete success, since the signal intensity of the ECE system is becoming smaller compared with before, but at least experience has been gained, and oblique ECE front end quasi-optical system has been installed, it provides the opportunity to the future studies of high-energy electron characteristics generated by LHW.

In the next year, an electron temperature gradient scale length ($L_{T_e} = T_e/|\Delta T_e|$) direct measurement system is planned, there will be no need of absolute calibration and the electron temperature profile fitting to get L_{T_e} . The conventional method to get L_{T_e} is to fit the electron temperature profile, during this procedure there is plenty of uncertainty. Alternatively, a method has been described to obtain L_{T_e} from a measured change in ECE intensity for a sweep in filter frequency [8]. This comes from the fact that the T_e change ΔT_e is proportional to the change in signal intensity, and the radial position change ΔR is proportional to the change in frequency. By using voltage controlled oscillator (VCO) as LO source, the LO frequency can be

preprogrammed in one shot. With a set of swept frequency filters, such as tunable yttrium iron garnet (YIG) filters, $L_{T_e}(R)$ at different radial positions can be obtained.

The current heterodyne system can not measure the electron temperature profile at the low field side when the toroidal field at the magnetic axis is smaller than 1.8 T. In the next year, a 16-channel heterodyne system will be installed, with a frequency range of 81 to 96 GHz, with channel separation of 1 GHz. This system can measure the electron temperature profile at low toroidal field, such as 1.6 T. The low toroidal field on EAST is an attractive regime for low q_{95} and high β_N discharges. In this regime, the LHW system and the NBI system can be used, also the ICRF third harmonics heating can be used. In the near future, a new ECH system with a frequency of 105 GHz will be installed. This ECH system can be employed in the lower toroidal field regime.

4 CECE system upgrade

A single ECE channel is unable to resolve small-amplitude electron temperature fluctuation above the noise floor due to the inherent thermal noise in standard ECE measurements. By correlating two radially closely spaced radiometer channels, the turbulent fluctuation signal can be retained while the uncorrelated thermal noise is eliminated. This technique, known as correlation ECE (CECE) has been utilized on many machines worldwide, such as Alcator C-Mod[9], DIII-D[10], Asdex-upgrade[11], J-TEXT[12], TCV tokamak[13]. CECE diagnostic provides a powerful technique for overcoming the noise limitations of stand ECE in measuring small amplitude temperature fluctuations. Recently CECE diagnostic has been used to measure the electron temperature fluctuation in the improved energy confinement mode (I-mode) discharge in Asdex-upgrade, and interesting phenomenon have been observed[14].

The CECE system has been changed from port G to port C, this port is very close to the 2.45 GHz LHW system, but far away from the 4.6 GHz LHW system. The LHW system can generate strong electromagnetic fields nearby, so the 2.45 GHz system can cause perturbation on the CECE instrument. However, the 2.45 GHz LHW system is seldom used because of the low power absorption at high electron density, so the CECE system can be used without interference in most of the discharges.

Several important upgrades need to be pointed out. The first upgrade is that another radio frequency (RF) module consists of LO and mixer unit has been installed, as shown in figure 2. The frequencies of the two LOs are 102 GHz and 114 GHz respectively, so the CECE system can cover the frequency range from 104 to 132 GHz. In the intermediate frequency (IF) unit, after the low noise amplifier, another 8 channel power divider is used, with eight narrow band filters (250 MHz) are used. The frequencies are 2, 2.2, 3, 3.2, 16, 16.2, 17, 17.2 GHz. The reason for this is that YIG filter can change frequency from 4 to 18 GHz, and if 8 channel YIG filters are all at high frequencies, such as above 15 GHz, the controller needs more current to drive the YIG filters, and sometimes the current is so large

that the YIG filter setting fails. Using these eight channel narrow band filters, more frequency range can be covered.

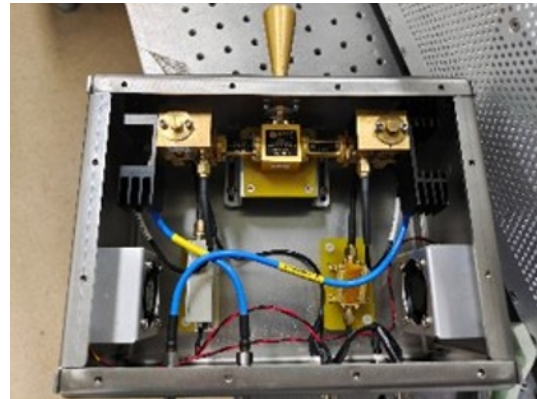

Figure 2. CECE RF unit with two LOs and mixers

The second upgrade is that a new RF transmission line was installed with lower power loss. The RF transmission line transfers the RF signal, which is the output of RF unit. The intensity of the RF signal is usually -10 to -40 dBm, and the frequency range is 2 - 18 GHz. The RF unit is close to the tokamak, just near the waveguide. However, the IF unit which converts the RF signal to the voltage signal is about 4 meters away from the RF unit. This long distance needs transmission line with low power loss, usually the attenuation should be less than 3 dB. The old transmission line has very high attenuation, about 10 dB, and this is not suitable for electron temperature fluctuation measurements, especially when the cross power spectrum is calculated, the high frequency (above 100 kHz) information will be lost.

The third upgrade is the intermediate attenuator between the two low noise amplifiers was properly chosen. In the past, the gain of the two amplifiers was 30 dB and 45 dB respectively, and the attenuator was 2 dB. Most of the time we can see no change in the output signal when the heating power is large. The reason is that the first amplifier was overdriving the second amplifier and this was fixed with a larger intermediate attenuator which is 10 dB. This means that the 1 dB compression point of the second amplifier needs to be considered. In the past, due to the absence of the high frequency wideband source, only the IF unit is tested. At this experiment campaign, we borrowed a noise source, and used it to make a complete system test, including both the IF and RF units. It proves that only with complete test, can the whole system work properly.

The CECE system can measure the electron temperature fluctuation at ρ from 0.7 to 1, this is the region where the electron temperature fluctuation is largest. Especially at the pedestal top, where ρ is about 0.85 to 0.95.

5 The high resolution ECE system

The new high resolution ECE system has been installed on port F, very close to the 4.6 GHz LHW system. The window for ECE measurement is very small, the diameter

is about 11 cm, and it is near the midplane. This system is intended to detect the 2/1 and 3/2 MHD modes, including tearing mode and neo-classical tearing mode. According to the typical mode location, the LO and filters are chosen. The system has eight channels, and the LO frequency is 118 GHz, and the frequency of eight narrow band filters (250 MHz) is very closely spaced. The frequency can cover 122 to 125 GHz, about 8 cm radially. There are many diagnostics in port F, the space is limited, ECE mirror support installation inside the vacuum chamber is not available. A curvature window and lens antenna are employed to improve the poloidal optical collection capability. The beam radius inside the chamber without curvature window is shown in figure 3, and the beam radius inside the chamber with curvature window is shown in figure 4. It can be seen that with curvature window, 3dB poloidal beam radius changes from 40 mm to about 20 mm, and is more centralized. Another feature is the use of the second harmonic mixer. This has never been used on EAST before. On future fusion devices, as the toroidal field is much higher, high frequency (above 200 GHz) LO and mixer will be used. Nevertheless, the high frequency LO and mixer is very hard to produce, so second harmonic mixer is a good candidate. Now the whole high resolution ECE system can obtain signal when there is slide away discharge with very low electron density, the output of the conventional ECE system usually reaches a saturation voltage (above 4 V), the output voltage of the high resolution ECE system is about 1 V. At normal discharge with moderate electron density, the output voltage is very small. This means that the output of the high resolution ECE system is much lower than that of the conventional ECE system, hence there are further improvements needed to obtain an optimally functioning system.

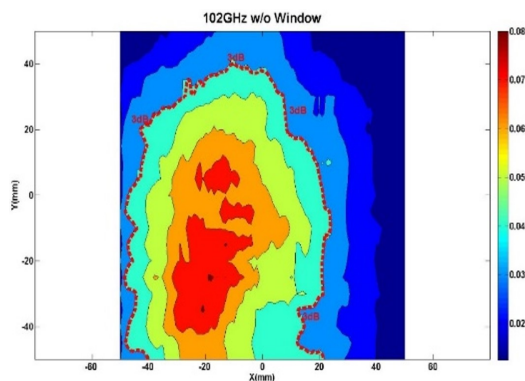

Figure 3. Beam radius inside the chamber without curvature window

6 Summary

The ECE system on EAST has been upgraded in year 2020. The main upgrade includes the front end quasi-optical system upgrade, comprised of two quasi-optical systems, one is for conventional ECE system, including 56 channel heterodyne system and Michelson interferometer, the other is for future oblique ECE system, which can

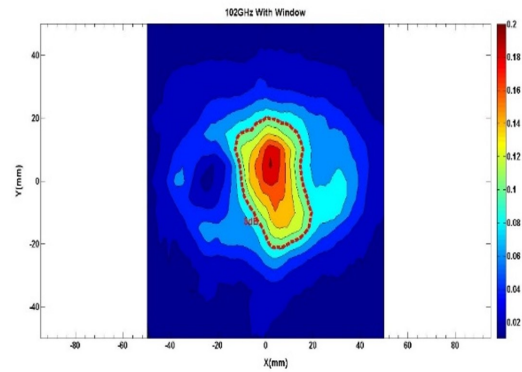

Figure 4. Beam radius inside the chamber with curvature window

be used for studies of high-energy electron characteristics generated by LHW. The transmission line also has been rearranged, after the upgrade, the signal intensity is smaller than before, partly because the surface area of the mirror is about half of the old mirror, partly because the transmission waveguide has more miter bends, it causes more power attenuation. The CECE system has been moved to port C and upgraded to 16 channel output, and two LO and mixer units have been installed to cover a wider frequency range. The CECE system is now physically closer to 2.45 GHz LHW system, but farther away from the 4.6 GHz LHW system. As the 2.45 GHz LHW system is less often used, the CECE system can operate without interference in more EAST discharges, and contribute more to physical research. A new high resolution ECE system has been installed in port F, the design of the optical system and the idea of improving the poloidal resolution have been verified, and the ability of the second harmonic mixer to work near the tokamak device is verified. However, to obtain good signal output, more work needs to be done.

In the next year, a L_{Te} directly measurement system is planned, there will be no need of absolute calibration and the electron temperature profile fitting to get L_{Te} . VCO will be used as LO and by scanning LO frequency, together with the change of YIG filter frequency, $L_{Te}(R)$ at different positions can be obtained.

Also, one 16 channel ECE system which covers 81 to 96 GHz with 1 GHz separation per channel is on schedule. This will measure the electron temperature profile for B_T smaller than 1.8 T. Low toroidal field discharge is very attractive especially with low q_{95} and high β_N .

Acknowledgments

This work was supported by the National MCF Energy R&D Program of China under contract Nos. 2019YFE03030002.

References

- [1] Lichtenberg A J, Sesnic S, Trivelpiece A W., Phys. Rev. Lett., **13**, 387 (1964)
- [2] Songtao Wu, EAST Team., Fusion Eng. Des., **82**, 463 (2007)

- [3] Yuntao Song et al., *Sci. Adv.*, **9**, eabq5273 (2023)
- [4] C. Hu et al., *Plasma Sci. Technol.*, **17**, 817 (2015)
- [5] Fukun Liu et al., *Nucl. Fusion*, **55**, 123022 (2015)
- [6] Xinjun Zhang et al., *Plasma Sci. Technol.*, **13**, 172 (2011)
- [7] Xiaojie Wang et al., *Fusion Eng. Des.*, **96-97**, 181 (2015)
- [8] S. Houshmandyar et al., *Rev. Sci. Instrum.*, **92**, 033510 (2019)
- [9] N.T. Howard et al., *Rev. Sci. Instrum.*, **85**, 118D11 (2014)
- [10] A.E. White et al., *Rev. Sci. Instrum.*, **79**, 103505 (2008)
- [11] S.J. Freethy et al., *Rev. Sci. Instrum.*, **87**, 11E102 (2016)
- [12] H. Zhou et al., *Rev. Sci. Instrum.*, **89**, 10H105 (2018)
- [13] M. Fontana et al., *Rev. Sci. Instrum.*, **88**, 083506 (2017)
- [14] R. Bielajew et al., *Phys. Plasmas*, **29**, 052504 (2022)