

# Physics-driven learning for digital holographic microscopy

Rémi Kieber<sup>1</sup>, Luc Froehly<sup>1</sup> and Maxime Jacquot<sup>1,\*</sup>

<sup>1</sup>Université de Franche-Comté, CNRS, FEMTO-ST Institute, 25000 Besançon, France

**Abstract.** Deep neural networks based on physics-driven learning make it possible to train neural networks with a reduced data set and also have the potential to transfer part of the numerical computations to optical processing. The aim of this work is to develop the first deep holographic microscope device incorporating a hybrid neural network based on the plane-wave angular spectrum method for dynamic image autofocusing in microscopy applications.

## 1 Introduction

Holography is an advanced coherent imaging method that combines the phenomena of diffraction and interference to restore a wavefront in amplitude and phase [1]. Digital processing of a hologram provides quantitative phase imaging, correction of set-up aberrations and digital refocusing without any mechanical displacement, thanks particularly to the angular spectrum method (ASM) of plane waves. These properties have made it possible, for example, to increase various degrees of freedom for the emergence of increasingly multimodal and automated 3D microscopy.

However, digital holography devices for microscopy are often based on off-axis configurations, incorporating a two-wave interferometer to produce amplitude and phase reconstruction from a single digital hologram. A more basic on-line configuration is also possible (Gabor holography), but requires more extensive post-processing to restore the image in amplitude and phase, or several acquisitions of the same phase-shifted hologram. Real-time hologram reconstruction is limited by heavy post-processing when the reconstruction distance is the unknown parameter, indeed, the hologram needs to be reconstructed digitally at each step along the out of plane axis and select the in-focus one. It is also worth mentioning that many computational imaging methods, such as ptychography, can restore a wavefront in amplitude and phase, or achieve super-resolution, but they often require a multitude of acquisitions of the same scene to reconstruct a single image, limiting their applications to quasi-static objects.

## 2 Deep digital holographic microscopy

The performance of these different approaches has been improved significantly in recent years thanks to deep neural networks [2]. One of the challenges is to reconstruct the information available in a hologram at high speed, in order

to carry out dynamic studies while guaranteeing the sensitivity offered by quantitative measurement of the optical phase. The most widespread approach is based on intensive training of the neural network using a large number of examples labelled in pairs (input values and output values from the network), provided by experimental measurements reproducing different scenarios or presenting different samples to be studied [3]. Data-based learning is still very effective, provided that the training phase is carried out using a huge quantity of images that are sometimes difficult to access through experience [4]. It is then possible to overcome these issues by increasing the number of image sets through transfer learning. These methods are extremely costly in terms of resources and often require the network to be re-trained regularly, as generalisation is not guaranteed and easily generates artefacts.

An alternative approach is to use deep neural networks with physics-driven learning, i.e. independent of a large input/output dataset. In this way, learning is based on physical operations to achieve the result by optimising the output value by comparison with the image presented as the input to the network [2]. The limited amounts of data given to the neural network during the training make it very specific to one type of data [5]. Different approaches can be considered based on untrained neural networks or even pre-trained ones [2]. For the untrained systems, only one single input image is used and is optimized until the neural network reaches the target value, meaning this approach is extremely specific regarding the injected input and much slower during the inference step. Physics-driven learning methods consist of having a set of input image data (without paired out ones), for the training, which can potentially result in a faster inference step. Usually, this type of network is quite specific, but its generalisation depends on the diversity of the images and the size of the dataset involved.

The aim of this work is to design the first digital holographic microscope incorporating a hybrid deep neural

\*e-mail: maxime.jacquot@univ-fcomte.fr

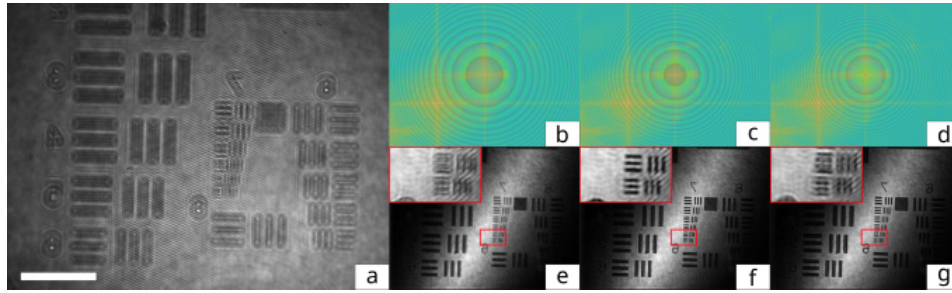
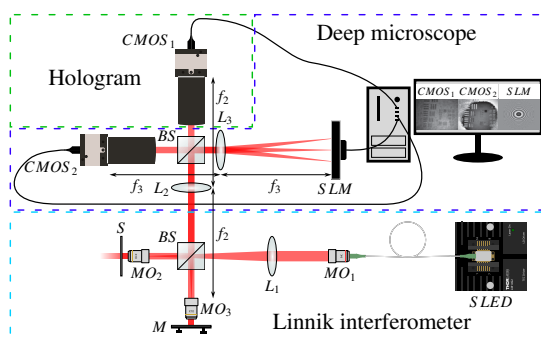

**Figure 2.** Examples of hologram reconstruction for 3 distances with the corresponding phase propagators. The sub-figure **a** correspond to an experimental off-axis digital hologram of a USAF 1951 resolution test chart. Sub-figures **b**, **c** and **d** represent the simulated digital propagators of the hologram for the reconstruction distances  $-54\ \mu\text{m}$ ,  $-74\ \mu\text{m}$  and  $-94\ \mu\text{m}$  respectively. The sub-figures **e**, **f** and **g** correspond to the numerical reconstruction in amplitude of the off-axis hologram at the distance  $-54\ \mu\text{m}$ ,  $-74\ \mu\text{m}$  and  $-94\ \mu\text{m}$  respectively. In the sub-figures **b**, **c** and **d**, the yellow peaks correspond to the 0 and +1 orders of the spectrum and the wrapped rings to the phase propagator, the propagator is centred on the +1 order. SLED@ $\lambda = 650\ \text{nm}$ , bandwidth  $\Delta\lambda = 6\ \text{nm}$ . Scale bar:  $100\ \mu\text{m}$

network architecture incorporating the ASM computing reconstructed method in the optical domain to restore a digital hologram for applications in dynamic image auto-focussing for automated 3D microscopy.

### 3 Method and preliminary results

A physics-driven learning scheme has been implemented to control optically the focusing at the output of an experimental digital holographic microscope in Figure 1. The optical back-propagation is carried through a deep neural network (U-Net). The ASM algorithm consists in propagating the field by applying a phase-only propagator (Figure 2) to the +1 order of the spatial Fourier transformed off-axis hologram. In Figure 2, we apply 3 different propagators on the hologram to illustrate the influence on the amplitude-reconstructed image.



**Figure 1.** Experimental set-up. SLED, Superluminescent Diode; MO, Microscope objective; L, Lens; BS, 50:50 Beam-splitters cube; M, Mirror; S, Sample; Camera CMOS; SLM, Phase spatial light modulator. SLM : X10468-17(X) from hamamatsu, composed of a matrix of  $792 \times 600$  pixels with a pixel pitch of  $20\ \mu\text{m}$  and a refresh rate of 60 Hz. CMOS<sub>1</sub> : UI-3480CP-M-GL Rev.2, composed of a matrix of  $2560 \times 1920$  pixels with a pixel pitch of  $2.2\ \mu\text{m}$ , a refresh rate of 15 Hz. CMOS<sub>2</sub> : UI-1490SE-M-GL, composed of a matrix of  $3840 \times 2748$  pixels with a pixel pitch of  $1.67\ \mu\text{m}$ , a refresh rate of 3.2 Hz. Intensity and phase images are displayed on the PC screen from the off-axis digital holography and numerical reconstruction.

In Figure 1, The lens  $L_3$  images the Fourier transform of the off-axis hologram in a microscopy configuration, in order to get the spectrum onto a SLM plane. The SLM displays the corresponding phase propagator to refocus the correct image, which depends only on the propagation distance, because the wavelength remains unchanged. The lens  $L_3$  allows a second optical Fourier transform onto the camera plane CMOS<sub>2</sub> from the field reflected by the SLM. The image recorded by the camera CMOS<sub>2</sub> generates the input of the neural network through the computer in order to update the phase mask displayed onto the SLM for the optimization process.

The architecture of the deep neural network used is a U-Net [5]. It is trained to determine the reconstruction distance by optimisation of the in-focused image generated by the SLM. As the network output is displayed on the SLM and then recorded by the camera, which is the input of the neural network, it creates a close loop that continuously increases the accuracy of the reconstruction distance. The camera CMOS<sub>1</sub> is used to record the off-axis hologram, to get the ground truth. The numerical ASM is applied to the off-axis hologram and compared to the image recorded on the camera CMOS<sub>2</sub> after the optimisation with the neural network. In this way, it is possible to estimate the robustness of physics-driven training process proposed.

### References

- [1] J.W. Goodman, *Introduction to Fourier Optics* (Roberts and Company Publishers, 2005), ISBN 978-0-9747077-2-3
- [2] K. Wang, L. Song, C. Wang, Z. Ren, G. Zhao, J. Dou, J. Di, G. Barbastathis, R. Zhou, J. Zhao et al. (2023), 2308.00942
- [3] S. Park, Y. Kim, I. Moon, *Optics and Lasers in Engineering* **167**, 107624 (2023)
- [4] S. Cuenat, L. Andréoli, A.N. André, P. Sandoz, G.J. Laurent, R. Couturier, M. Jacquot, *Opt. Express*, OE **30**, 24730 (2022)
- [5] F. Wang, Y. Bian, H. Wang, M. Lyu, G. Pedrini, W. Osten, G. Barbastathis, G. Situ, *Light Sci Appl* **9**, 77 (2020)