

Optimization of Machining Operation Sequence Problem using an Integrated Genetic and Simulated Annealing Algorithm

M Venkatesan^{1*}, *A karthikeyan*², *J Vinoth Kumar*³, *S Muthuvel*⁴, *D Vasudevan*⁵, *A Sankar*⁶

¹Associate Professor, Department of Mechanical Engineering, Excel Engineering College, Komarapalayam - 637303, Tamil Nadu, India

²Associate Professor, Department of Aeronautical Engineering, Excel Engineering College, Komarapalayam - 637303, Tamil Nadu, India

³Assistant Professor, Department of Mechanical Engineering, Bannari Amman Institute of Technology, Sathyamangalam - 638 401, Tamil Nadu, India

⁴Professor, Department of Mechanical Engineering, Kalasalingam Academy of Research and Education, Krishnankoil - 626126, Tamil Nadu, India

⁵Associate Professor, Department of Mechanical Engineering, K.S.Rangasamy College of Technology, Tiruchengode - 637215, Tamil Nadu, India

⁶Assistant Professor, Department of Agricultural Engineering, Dhirajlal Gandhi College of Technology, Salem – 636309, Tamil Nadu, India

Abstract. Among the most important and difficult tasks in CAPP (computer-aided process planning) is optimizing the machining operation sequence, which calls for a lot of iterations and a significant amount of computational time. Decreasing the frequency of tool changes and machine setup iterations is the primary goal of improving the machine operation sequence. To solve the CAPP problem and determine the shortest manufacturing time, this study suggests a hybrid approach called the integrated genetic and simulated annealing (IGSA) algorithm. The best sequence with the shortest manufacturing time, discovered in the first algorithm (genetic), has been proposed to be the starting sequence of the second method (simulated annealing), which searches for neighbouring ideal sequences. The feasible solutions for a given issue are the best sequences that can be found using this integration technique. The performance of the suggested IGSA algorithm was tested, including various benchmark problems with simple precedence constraints. The comparisons of benchmark and case study results with other existing algorithms in the literature show a drastic improvement in the computational time and optimal solutions.

1 Introduction

Numerous research techniques have been employed in recent decades to use CAPP to tackle optimization challenges. A comprehensive survey was made to identify where computer

* Corresponding author: venkatesanm1972@gmail.com

application is possible and where human operators have marked average [1]. For a single machine, the setup cost between two operations was studied. Latin multiplication method was used and the cost was reduced by introducing alternate plans [2]. During the planning process, the computer is used to sequence the machining operation to reduce cost. The STEP-NC data was used for roughing and finishing operations [3]. Using CAPP, an alternate optimum solution for sequencing operations was made with a tree-structured approach [4]. In the machining sequencing problems, different optimization techniques and algorithms are used to reduce operation time for optimum requirements. A discrete swarm optimization (DPSO) method is used to minimize setup time on the multi-head surface mounting machine (SMM) [5]. The MATLAB program was used for optimizing the sequencing problem, compared with other optimization techniques and algorithms, and proved faster and better results [6]. In a CAPP study, the ant colony algorithm technique was used to find operation sequence optimization in a couple of case studies. The alternate sequences that were found were same time and with low cost [7]. The scheduling and sequencing of large-scale job shop operations is a difficult task. In a study, the alternate route for the bill of materials (BOM) was made based on variable neighborhood search (VNS). The approach was then compared with the GA and concluded the method is suitable for large and single BOM [8]. For the minimum operating cost, the honey bees mating optimization (HBMO) algorithm was implemented in a process planning problem. It was performed in three experiments and the results demonstrated that the dominant and better results than additional algorithms [9]. A large-size constraint-based sequencing problem was optimized using a tabu search-based approach. Case studies were made and results were contrasted with genetic as well as annealing algorithms. The tabu search-based approach showed better performance and quality results [10]. A MDTS (multi-dimensional tabu search) algorithm was used for optimizing sequencing and machining problems. The results were compared with SA (simulated annealing), GA (genetic algorithm), and TS (tabu search) and showed quality and efficiency [11]. Using a modified clustering algorithm, three case studies were made for optimizing sequence problems. The optimized result showed that the operation time was significantly reduced and more optimum solutions were obtained [12]. The genetic algorithm (GA) is frequently employed, and it was found that computation time for optimizing sequencing was low and alternate optimum solutions can be made fast and effective [13]. The GA is used for the rapid and optimum feasible solution in the CAPP applications. In addition, artificial intelligence (AI) was introduced and showed increasing performance [14]. The TSPPC (traveling salesman problem with precedence constraints) is much more difficult to attain and also many possible and optimum solutions. The GA was applied on TSPPC and it was found a superior performance than the traditional one [15]. An experimental study was conducted in a job shop and the GA was applied for sequencing operations of 23 operations. On a challenging problem, it was discovered that the GA algorithm operated effectively and consistently. The activity-based scheduling optimization problems are reviewed and found that GAs were used frequently for effective solutions. The optimization problems that are bound-constrained and unconstrained can be resolved using the SA approach. In hydrogen production, a permeability model is optimized using the SA algorithm. SA was utilized in a case study to optimize routing and sequencing, and the outcomes were contrasted with those of a GA. It was found that the SA is effective compared to the other approaches. Two prismatic parts were studied for optimum sequence solution with SA algorithm, GA, and tabu search algorithm. The ACO (ant colony optimization) algorithm was found to be more effective than the other three algorithms. Similarly, for controlling the reactive power system, three prismatic parts were studied for optimum sequencing using the PSO (particle swarm optimization) algorithm. The altered PSO algorithm generated an efficient optimal solution for less time compared to the GA as well as simulated algorithm. A simple SA algorithm was applied to three case studies and found that the SA produced an efficient and optimum

solution in less time. Recently an adaptive SA algorithm was proposed on an experimental job shop sequence and found that the developed algorithm is more effective. An approach that blends two or more different algorithms to solve a single problem is called a hybrid algorithm. The branch and fathering (B&F) algorithm demonstrated a significantly better solution in a shorter amount of time. For the best process plan and minimum makespan, a hybrid dynamic DNA (HD-DNA) algorithm technique has been created, which has improved the manufacturing system's efficiency. A hybrid CSG (cuckoo search-genetic) algorithm was used for sequencing operations of hole-making. The solved computational test results showed an improvement than other algorithms. A sequence optimization problem was proposed with a PSO algorithm. The numerical experiments and comparison results showed good quality and efficiency. The machining processes in a case study have been sequenced utilizing a GA and SA algorithm. The results showed the satisfactory results of the hybrid approach. The most well-known solution to the mTSP (Multiple Traveling Salesman Problem), which is to reduce the longest tour's length, has recently been improved by a hybrid GA. Numerous studies have been conducted in the field of operations sequence optimization. There is still room for improvement in this suggested approach, even after employing a number of unconventional meta-heuristic strategies. These enhancements can be achieved by combining genetic and SA algorithms to uncover alternative sequences, minimize machine costs, reduce computing time, and make constraint implementation simple.

2 Implementation of IGSA Algorithm

Depending on Darwin's "survival of the fittest," the GA may be utilized to a broad range of real-world issues. It is a metaheuristic method for looking for answers in a global random space, but it can also waste more computing time and trap in local minima. High fitness solutions can endure in the global environment. The SA algorithm is combined with GA to get around this limitation. By haphazardly reversing the 2 sets of variables, the SA method can find the closest optimal sequence by starting with the best sequences found by the GA. This kind of searching aids in the solutions' escape from local minima. This integration will decrease the algorithm's total computing time. The details of the proposed algorithm are presented below, and the flowchart is illustrated in Figure 1. The effect of various parameters of both algorithms is studied and included in this work considers one of the case studies that has 3 operations along with precedence constraints. The major parameters involved in the GA are reproduction probability, crossover probability, mutation probability, population size, no of generations, types of crossovers and mutation operators, fitness functions, and the combination of various mentioned parameters, which are very important in solution convergence and execution time. All benchmark case studies and application issues were resolved using these parameters. According to the computational tests, GA looks for the solution at random in the search space, but it occasionally finds local minimum solutions. It also requires more computing time and could not be appropriate on its own for optimization problems involving more than ten processes. By avoiding local minimum solutions, a hybrid with a SA algorithm will assist in locating the best or nearly ideal solutions. Achieving globally optimal results requires the confluence of GA and SA.

The suggested IGSA algorithm was built in 800 lines of code using Turbo C++ and executed on a 1.7 GHz Core 2 Duo CPU including 4 GB of RAM. The suggested technique has been computationally verified on eight case studies and three benchmark problems to confirm its performance and practicality. Together with the optimal genetic and SA algorithm parameters derived from earlier computational investigations, the component PCM is sent as input to the algorithm.

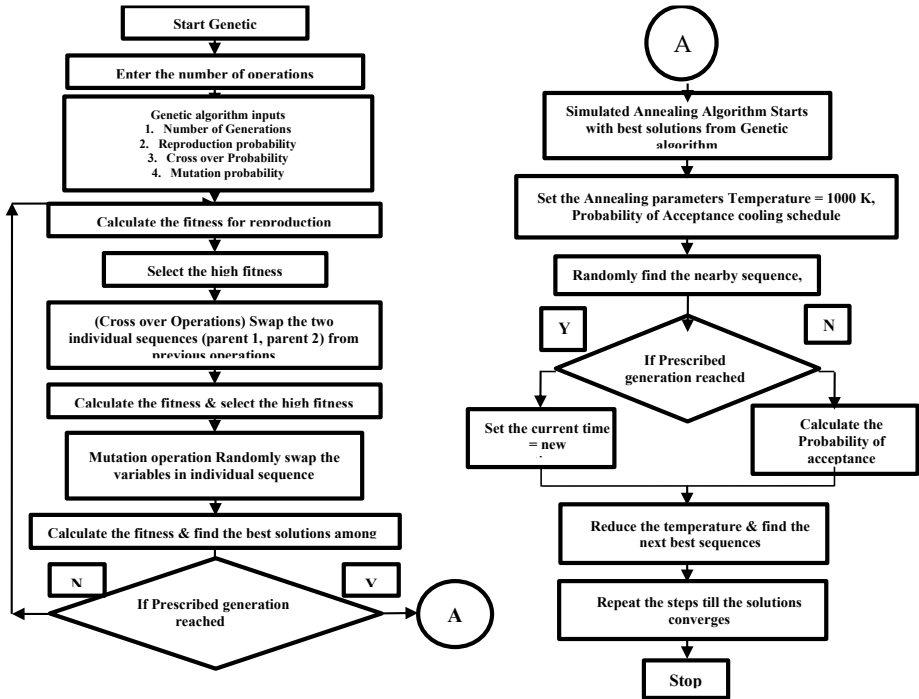

Fig. 1. Flow chart of proposed GISA algorithm

3 Case studies for performance testing

For testing the proposed algorithm performance, three application-oriented components were considered from the literature. The test results and performance were compared with the literature algorithms like GA, ant colony algorithm, SA, PSO algorithm, and cluster algorithm. The parameters considered for comparisons are optimal production time, number of alternative sequences, and computational time.

3.1 Case study 1

For demonstration of the performance of the suggested algorithm having 13 operations. The details of the 13 operations and the corresponding machining process are represented in Table 1 below.

Table 1. Machining operations details of case study 1 for 13 operations

Descript ion	1	2	3	4	5	6	7	8	9	10	11	12	13
Operatio ns name	Cyl 1	Cyl 2	Cyl 2	Cyl 3	Cyl 3	Face 1	Thread	Groove 1	Hole 1	Hole 12	Hole 12	Hole 74	Hole 74
Machine setup	Rough		Finish		Rough	Finish		Pre	finish			Rough	
Machine	Lathe								Drill				

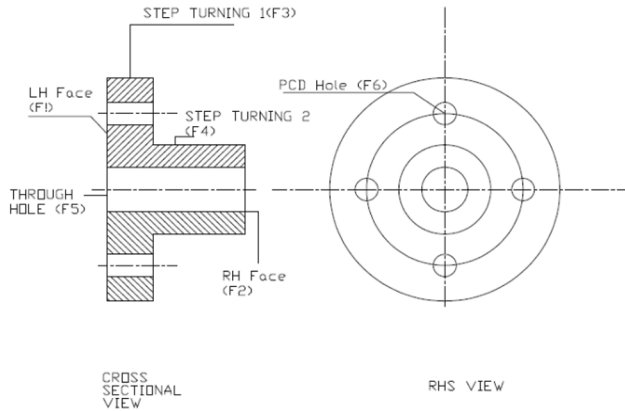

Fig. 3. Case study 2 - Rotational component with 6 operations

Table 3. Precedence cost matrix of case study 2 for 6 operations

	1(F1)	2(F2)	3(F3)	4(F4)	5(F5)	6(F6)
1(F1)	999	1	0	1	11	100
F2(2)	1	999	1	0	11	100
F3(3)	1	1	999	0	11	100
F4(4)	1	0	999	999	11	100
F5(5)	11	999	11	11	999	100
F6(6)	999	999	999	999	999	999

The optimal sequence was (1,3,4,2,5,6) and the optimum cost was 122. Table 5 compares the suggested algorithm including additional algorithms. This method is 100% faster than the previous method.

3.3 Case study 3

Another case study was taken from the literature Reddy. S.V.B. et al. [13], having ten operations along with technical specifications as shown in Figure 4. The precedence cost matrix for 6 operations of case study 3 is shown in Table 4.

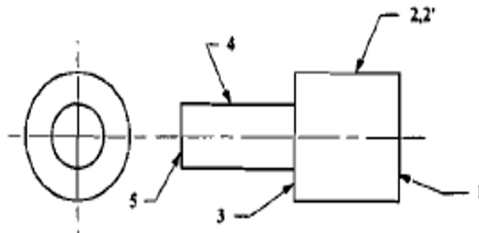

Fig. 4. Case study 3 - Rotational component with 6 operations

Table 4. Case study 3 - Precedence cost matrix for 6 operations

	1	2	3	4	5	6 (2')
1	X	X	X	1	1	1
2	1	X	X	X	1	1
3	X	X	X	X	1	1
4	X	X	1	X	1	1
5	1	X	1	1	X	1
6 (2')	1	X	1	1	1	X

The best results obtained in the Latin multiplication method and proposed IGSA is given below. The few optimal sequences obtained are, with optimum cost is 5.

(2,6,1,4,5,3), (2,1,4,6,3,5), (2,1,4,3,6,5), (2,1,6,4,3,5), (2,5,1,6,4,3), (2,6,1,4,3,5), (2,5,1,4,6,3),
 (2,5,6,1,4,3), (2,1,6,3,5,4), (2,5,4,3,6,1), (2,1,6,4,5,3), (2,5,4,3,6,1), (2,1,4,6,5,3), (2,6,3,5,1,4),
 (2,1,4,3,5,6), (2,5,6,1,4,3), (2,1,4,5,3,6), (2,1,4,3,5,6), (2,5,1,6,4,3), (2,6,1,4,5,3).

4 Results and discussion

The proposed IGSA algorithm applies to complicated practical applications with many machining operations and more precedence constraints. The obtained sequence satisfies all pre-constraints. The optimal cost obtained in case study 1 is 1200 units which is than BFA algorithm Lee, D.H. et al. [25]. But the computational time is drastically reduced to below 3 sec which is an 80% reduction as compared to the GA alone. There are many alternative sequences obtained in which solutions are similar in the literature few of the sequences are (2-6-3-5-8-9-7-4-1-12-13-10-11), (2-4-6-3-5-9-8-7-1-12-13-10-11), (2-4-6-3-5-8-9-7-1-12-13-10-11), (2-4-6-5-3-9-8-7-1-12-13-10-11). The result which is shown in case study 2, with six operations is 122 units in 7.51 sec. The optimal sequence was obtained (1-3-4-2-5-6). The proposed IGSA algorithm is the same as 122 units in 3 sec with two sequences (5-1-3-4-2-6) and (1-3-4-2-5-6). The computational time is reduced by 60% as compared to Irani, S.A. et al. [2]. In case study 3, Prabhu, P. et al. [4], from 720 combinations (6!) the optimum sequence is reduced to 20 for the optimum cost of 5. 40% of the time is reduced compared to the literature. A few of the optimum sequences obtained are (2-6-1-4-5-3), (2-1-4-6-3-5), (2-5-1-6-4-3), (2-1-6-4-5-3). In all the case studies the suggested IGSA algorithm performs much better than additional algorithms consequently computational time and alternate sequences which is shown in Table 5. In a few case studies, optimal solutions are improved as compared to previous algorithms. The execution time is drastically reduced and many alternative sequences were obtained. All the above tests were carried out in 10 to 20 trials to verify the optimal solutions to the standard literature problem. Among various algorithms (GA, ACA, S-GENSAT, SA) in the literature, the suggested GISA algorithm can able to solve all the case studies with shorter computational time, and also many alternate sequences were obtained in this method. The superior characteristic of this algorithm are neglect of all the individual infeasible solutions in each iteration. Due to this high computational efficiency and easy implementation of precedence constraints, this proposed GISA algorithm is superior to another algorithm. Compared to other algorithms, this suggested IGSA performs better. In addition to finding a large number of viable alternative answers in the global search space, this combination converges relatively quickly. It is an extremely straightforward and effective technique that can easily apply any type of precedence restrictions to solve globally optimal solutions. After giving the inputs such as the cost matrix along with precedence constraints, the solutions were automatically computed in the Turbo C++ algorithm.

The consolidated summary results are given in Table 5 below.

Table 5. Consolidated results summary of all case studies.

Author	Method	Optimum cost (unit)	Convergence time (sec)	No. of alternate optimal sequences
Case study 1				
Lee, D.H. <i>et al.</i> [25]	BFA	1250	29.95	many
Proposed	IGSA	1200	3	many
Case study 2				
Irani, S.A. <i>et al.</i> [2]	HP	122	7.51	1
Proposed	IGSA	122	<3	1
Case study 3				
Prabhu, P. <i>et al.</i> [4]	LMM	5	5	14
proposed	IGSA	5	<2	20

5 Conclusions

This approach would not produce any impractical sequences at any point throughout iteration because it thoroughly verifies the precedence requirements right from the start. This algorithm will be able to meet the solution's stopping criterion with the aid of the acceptance probability. This study shows the importance of a meta-heuristic method in the milling and turning center's machining operations optimization. Numerous case studies from the standard literature demonstrate the effectiveness of the suggested CAPP methodology. The comparison demonstrates that the best results are frequently found in the literature with a more practical sequence and less computing time. One of the key efforts in this field is parameter optimization, which may determine the ideal range of parameters for resolving any type of issue. Integrating precedence constraints (fixed and dynamic) into process design is another crucial topic. This allows for the generation of workable solutions at every level without going against the precedence constraints. With a chance of acceptance through the selection of high-fitness solutions in both algorithms, the hybrid genetic and SA algorithm's unique features may shorten computing time. Because GA suffers, hybridization is essential to achieving globally optimal results. The IGSA algorithm will work better with more pre-constraints that increase complexity, leading to a notable improvement in both computational time and outcomes.

References

1. Weill R, Spur G, Eversheim W. Survey of Computer-Aided Process Planning Systems. CIRP Ann - Manuf Technol. 1982;31(2):539–51
2. Irani SA, Koo HY, Raman S. Feature-based operation sequence generation in CAPP. Int J Prod Res. 1995;33(1):17–39
3. Mokhtar A, Xu X. Machining precedence of 21/2D interacting features in a feature-based data model. J Intell Manuf. 2011;22(2):145–61
4. Prabhu P, Elhence S, Wang H, Wysk R. An operations network generator for computer aided process planning. J Manuf Syst. 1990;9(4):283–91

5. Chen YM, Lin C-T. Optimizing the Operation Sequence of a Multihead Surface Mounting Machine Using a Discrete Particle Swarm Optimization Algorithm. Poli R, editor. *J Artif Evol Appl*. 2008; 315950. Available from: <https://doi.org/10.1155/2008/315950>
6. Singh S, Deb S. An intelligent methodology for optimising machining operation sequence by ant system algorithm. *Int J Ind Syst Eng*. 2014;16(4):451–71
7. Krishna AG, Mallikarjuna Rao K. Optimisation of operations sequence in CAPP using an ant colony algorithm. *Int J Adv Manuf Technol*. 2006;29(1–2):159–64
8. Sobeyko O, Mönch L. Integrated process planning and scheduling for large-scale flexible job shops using metaheuristics. *Int J Prod Res*. 2017;55(2):392–409
9. Wen XY, Li XY, Gao L, Sang HY. Honey bees mating optimization algorithm for process planning problem. *J Intell Manuf*. 2014;25(3):459–72
10. Li WD, Ong SK, Nee AYC. Optimization of process plans using a constraint-based tabu search approach. *Int J Prod Res*. 2004;42(10):1955–85
11. Lian K, Zhang C, Shao X, Zeng Y. A multi-dimensional tabu search algorithm for the optimization of process planning. *Sci China Technol Sci*. 2011;54(12):3211–9
12. Phung LX, Van Tran D, Hoang SV, Truong SH. Effective method of operation sequence optimization in CAPP based on modified clustering algorithm. *J Adv Mech Des Syst Manuf*. 2017;11(1):1–12
13. Reddy SVB, Shunmugam MS, Narendran TT. Operation sequencing in CAPP using genetic algorithms. *Int J Prod Res*. 1999;37(5):1063–74
14. Dereli T, Filiz IH. Optimisation of process planning functions by genetic algorithms. *Comput Ind Eng*. 1999;36(2):281–308
15. Moon C, Kim J, Choi G, Seo Y. An efficient genetic algorithm for the traveling salesman problem with precedence constraints. *Eur J Oper Res*. 2002;140(3):606–17