

Modern Measurements of Fission Reactor Power Spectral Density

Gilles Caulier*, Romain Boffy, Maxime Dutertre, and Jean-Paul Goossens
CEA, DES, IRESNE, Department of Reactor Studies,
Cadarache F-13108 Saint-Paul-Lez-Durance, France
(*) gilles.caulier@cea.fr

Abstract—Power spectral density measurement techniques allow to derive information on nuclear reactors. In specific conditions, one can obtain reactor’s kinetic parameters. At IRESNE institute, located at CEA Cadarache, the researchers of the Department of Reactor Studies have used for many years X-MODE and SPECTRON Data Acquisition systems (DAQ) to measure power spectral densities. Due to electronic components, computer, and software obsolescence, the Department started a refurbishment program. The new SCHMITT DAQ replaces X-MODE. It is based on a CAEN R7771 neutron pulse train recorder device, an industrial Linux computer, and a custom-made software. The latter, developed by the Department, is in charge of acquisition setting, data recording, post processing, and visualization. The paper describes the development of the SCHMITT DAQ. The software is written in an object-oriented approach and based on Qt framework for enhanced code portability and to allow using new standard software technologies. This new DAQ has been successfully completed and is ready to for a future qualification and usages. Current developments aim at including support for advanced nuclear data post-processing.

Keywords — Neutron Noise; Reactor Kinetic; PSD

I. INTRODUCTION

FOR safety reasons, it is important to predict correctly the kinetic behaviour of LWRs in nominal or incidental situations. When a nuclear reactor is near criticality, the delayed neutrons kinetic drive the neutron production. Integral parameters, such as the reactor reactivity, are calculated by computational tools which make use of a nuclear data library. To compare calculation results to the experimental values, it is possible to use nuclear research reactors at low power in well characterized configurations.

In the past years, the IRESNE institute, which is part of the French Alternative Energies and Atomic Energy Commission (CEA) at Cadarache, has been leading research activities focusing on producing better evaluations of delayed neutrons nuclear data, by means of summation calculations [1], microscopic measurements [2] or integral measurements in research reactors [3 – 6]. Some of these integral measurements relied on the power spectral density measurement by mean of “pile noise” techniques. The analysis of power spectral density allows to derive reactor’s kinetic parameters such as the prompt

decay constant, α_p , or the effective delayed neutron fraction, β_{eff} .

The two legacy DAQs often employed in pile noise experiments by IRESNE team were X-MODE [7] and SPECTRON [8]. The former was dedicated to experiments in counting mode and the latter to experiments in current mode. This paper presents the replacement of X-MODE by the new SCHMITT DAQ. The section II presents the new SCHMITT DAQ, its hardware and its software architecture, section III presents some elements of in-laboratory qualification, and section IV draws the key elements of this modernisation program as well as future developments.

II. THE NEW SCHMITT DAQ

A. Hardware architecture

The portable measurement system SCHMITT inherits its operating principles from the X-MODE system designed in the early 2000s. Due to its obsolescence, a redesign study was initiated at the end of 2022. The SCHMITT system is intended to replace and improve the X-MODE acquisition system. Its operational context involves acquiring TTL signals during reactor experiments. TTL is a logic signal in tension resulting from the discrimination of an amplified pulse coming from a detector. Figure 1 shows the X-MODE system on the left and the SCHMITT system on the right.



Figure 1. The legacy X-MODE DAQ on the left and new SCHMITT DAQ on the right.

Given that dead time in such experiments must remain below a certain threshold, these experiments typically involve low-power measurements or less sensitive detectors. The X-MODE system had a limitation of approximately 200 kc/s, whereas SCHMITT's limit is set at 3 Mc/s. Figure 2 illustrates the hardware architecture of SCHMITT. The complete

measurement system comprises detectors inserted in the reactor, signal shaping electronics, the counting and timestamping unit CAEN model R7771 [9], and a Linux PC for acquisition control. The input signals to the R7771 module must be in a 0-5 V TTL logic form.

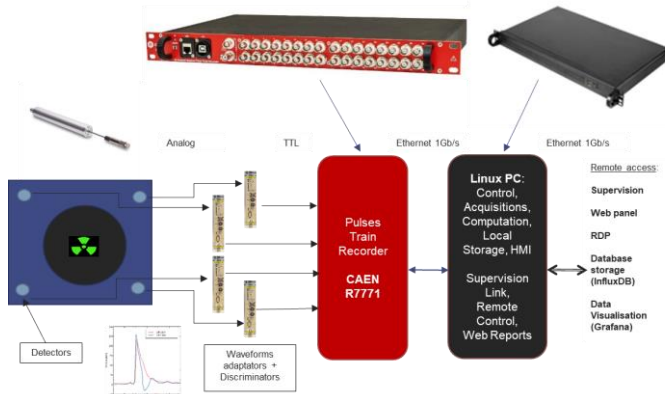

Figure 2. The Measurements Chain from the Detectors to the Data Acquisition Unit.

B. Software architecture

The project uses a modular architecture based on Qt [10], C++, and CMake. It includes a vast collection of unit tests and extensive data collection, with all dependencies being open-source. The application is distributed as an AppImage for Linux and comprises approximately 100,000 lines of source code, requiring about 22 person-months for its development. The Human-Machine Interface (HMI) is designed to be streamlined and intuitive with well-separated experimental functions. It uses sidebar tabs and stacked views throughout. The graphs support zooms and pan, and the interface is ready for internationalization to facilitate translations. Figure 3 shows the main view of the DAQ software.

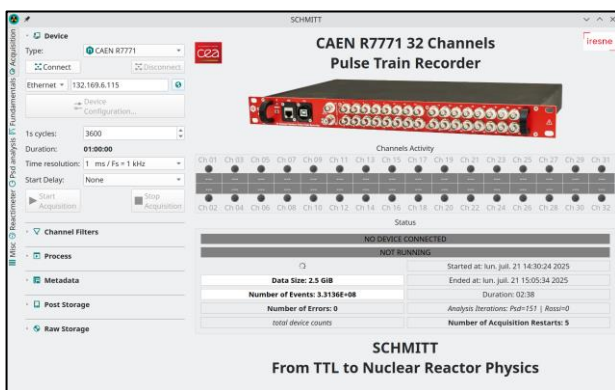

Figure 3. SCHMITT software main view.

The system offers advanced computing capabilities, including multi-core and multi-thread processing, along with a continuous workflow for data analysis and the generation of experiment graphs. It offers several modes, such as device measurements, a neutron noise simulator, a divergence simulator, and the ability to replay previous measurements. Additionally, it is capable of handling a variety of nuclear data, thus offering great flexibility in its use.

The key features related to computations includes count rate measurement, multiplicity, and the analysis of time intervals. It also presents several homemade algorithms, such as power spectral density (PSD) methods, including automatic fit. Another tool can be used to compute the inline nuclear reactivity with error bar indicators to assess measurement uncertainty.

The system supports background processing of big data as well as multi-threaded processing. It manages local files, whether they are textual or binary, and may record data in an InfluxDB database. Regarding the network, it allows remote control via VNC, web report generation, and has a supervision interface. Additionally, remote data storage is also done via InfluxDB.

Figure 4 shows the main components of the software architecture. It comprises nine primary components, each operating within separate threads to ensure efficient processing. The input data for the system can be sourced from R7771, pile noise generator, divergence simulator, or recorded files. A robust communication pipeline facilitates the data stream between the various analysis components, ensuring seamless data flow and interaction. Central to this architecture is a controller that manages the overall data workflow, orchestrating the operations and interactions between the components to maintain a coherent and efficient processing environment.

The input data can be pipelined to three computation components, namely “Fundamentals”, “PSD” and “Reactimeter. The Fundamentals component comprises count rate, time-interval and multiplicity analysis. The PSD component proceeds to power spectral density analysis, a.k.a. Cohn-alpha analysis. APSD or CPSD may be chosen depending on one’s needs. Finally, the Reactimeter component computes the reactivity using a linear solver applied to the logarithm of count rate.

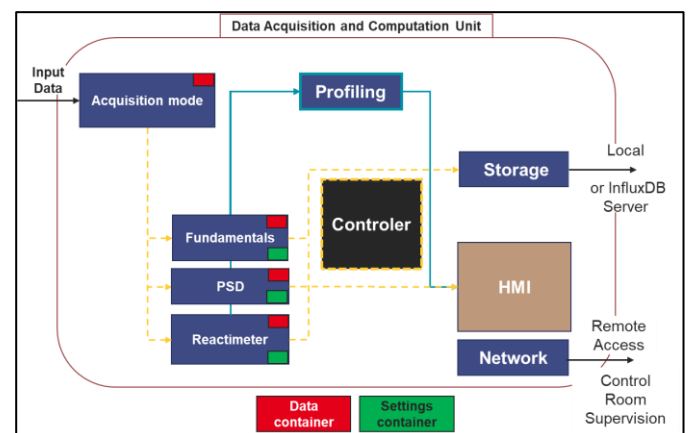

Figure 4. Software architecture

The controller is designed to manage multiple working threads, capable of handling more than 20 threads in parallel to ensure efficient processing. The pipeline facilitates data

propagation in discrete blocks or packets, with a slight delay of a few seconds to manage the data flow effectively. This pipeline is built on the Qt inter-thread communication framework, utilizing the signal/slots mechanism to coordinate data transmission between threads. Additionally, the pipeline employs a Flip/Flop input buffer to further optimize data handling and processing.

Figure 5 provides a summary on the parallelized computation architecture for kinetic profiles of a reactor. It features an input buffer that receives temporal data packets for analysis. When the buffer is filled, every second, the data is sent to update the curves, initiate the power spectral density calculations, and perform archiving on the disk. The PSD buffers stack the results of the profiles, which will be reused in subsequent computation cycles. The buffers consist of two flip-flop First-in-first-out (FIFOs) storing packets protected by mutexes. The first buffer stores incoming data, while the second stores data to be processed. This kind of architecture allows to proceed a large amount of data buffered in the memory. Note that architecture is also the same for all other computation modules.

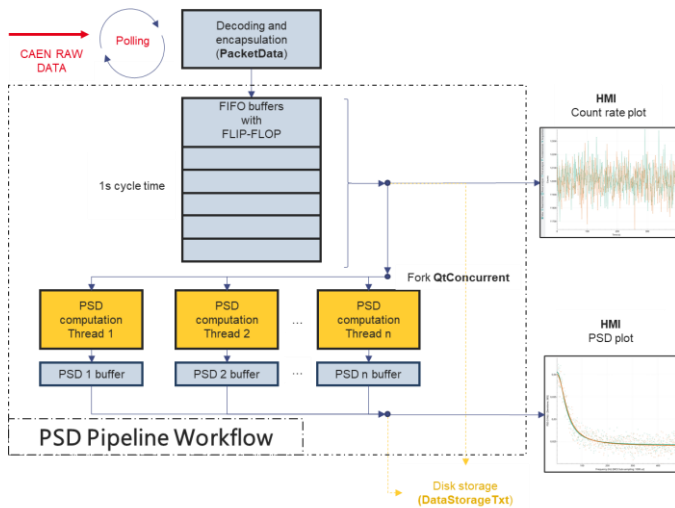

Figure 5. Details of the PSD Pipeline Workflow

III. RESULTS

The Figure 6 shows a linearity curve obtained from a count rate measurement. A TTL pulser was used as input with a rate from 10 c/s to 3×10^6 c/s. The pulser frequency was set constant, *i.e.* without Poisson distribution. The SCHMITT was able to follow the pulser without bias on the whole frequency range. It shows comparable performances when post-treating the recorded timestamps.

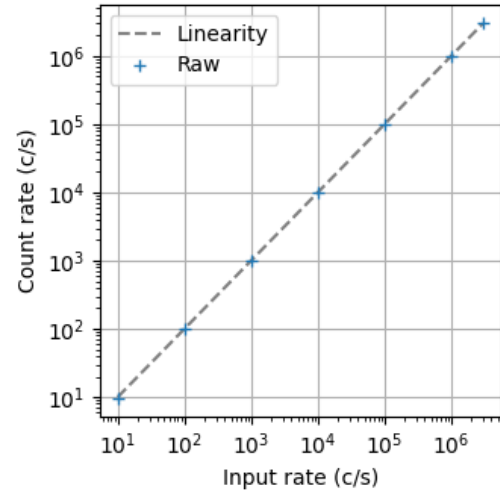

Figure 6. Count rate plot with a constant frequency input.

Figure 7 shows the PSD tab during a pile noise simulation with PSD analysis activated. The pile noise generator was set with 10 kc/s of white noise on channels 1 and 2, with an additional 1 kc/s of correlated noise to mimic the correlated signal coming from a reactor [11]. The relative amount of correlated noise was set relatively high to minimize to simulation time. The simulated prompt decay constant was set to 250 s^{-1} . The “PSD component” was set to compute APSD from channels 1 and 2, orange and green curves respectively, and the CPSD from them, purple. After each computation, the software proceeds to data fitting with the following Lorentz-like function, Y_{PSD} , from which it derives α_p

$$Y_{PSD}(f) = \frac{A}{1 + \left(\frac{2\pi f}{\alpha_p}\right)^2} + C$$

The fitting procedure converges correctly and the derived α_p compares relatively well with the noise generator settings.

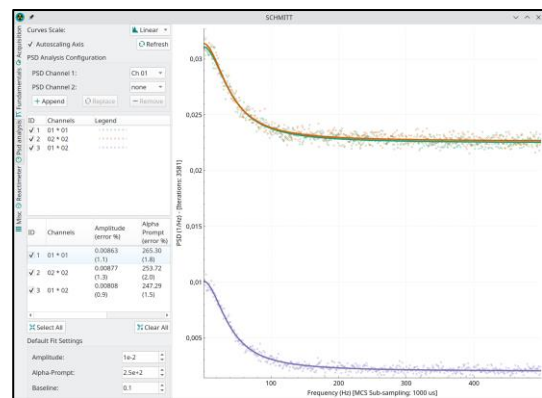

Figure 7. SCHMITT software view from PSD analysis and fit. Pile noise generator set with 10 kc/s of white noise, and 1 kc/s of correlated signal on which $\alpha_p = 250 \text{ s}^{-1}$.

Table 1 gathers computation performances with the Reactimeter and PSD components. The PSD process with two channels consists in three individual PSD computations, as in Figure 7, and the PSD process with four channels is the double. One has to recall that a data packet has to be processed every

second. The DAQ is able to process the requested PSDs quickly enough to keep up with the data input rate.

TABLE 1
 SOME PERFORMANCES OF THE SCHMITT DAQ.

Channels	Count rate per channel	Process	Time ^a
1	10 kc/s + 10 pcm	Reactimeter	0.040 ms
2	100 kc/s	PSD ^b (F _s = 1 kHz)	2.7 ms
4	100 kc/s	PSD (F _s = 1 kHz)	3.8 ms

^a On desktop Linux machine 12 cores, 2 threads / core, 3.8 GHz

^b PSD = Power Spectral Density, F_s = sampling frequency

IV. CONCLUSION AND PERSPECTIVES

The SCHMITT data acquisition system is built with of-the-shelf hardware components that are a R7771 CAEN pulse train recorder device and a Linux industrial computer. The acquisition software is CEA-made and based on a modular architecture based on Qt, C++, and Cmake. In addition to the data recording, it may proceed to online analysis such as count rate, time interval distribution, multiplicity, reactimeter and power-spectral density. The SCHMITT DAQ replaces the X-MODE DAQ, developed in 2000's, with an increased maximum count rate and online PSD computation capability.

The future developments will focus on the integration of a Rossi- α algorithm in order to be able to proceed simultaneously to pile noise analysis in the time domain (Rossi- α) and in the frequency domain (Cohn- α). Finally, thanks to the modular architecture of the software it is envisaged to support other hardware such as SPECTRON which is dedicated to low noise current measurement.

ACKNOWLEDGEMENTS

This study was funded by the French research institute CEA, EDF and Framatome.

REFERENCES

- [1] P. Leconte *et al.*, “New delayed neutron group constants and covariances for LWR core applications, combining summation calculations and integral experiments,” *Ann Nucl Energy*, vol. 139, no. 139, p. 107250, May 2020, doi: 10.1016/j.anucene.2019.107250.
- [2] B. Geslot *et al.*, “Measuring the delayed neutrons multiplicity and kinetic parameters for the thermal induced fission of ²³⁵U, ²³⁹Pu and ²³³U,” *EPJ Web Conf*, vol. 253, p. 01004, Nov. 2021, doi: 10.1051/epjconf/202125301004.
- [3] E. Gilad *et al.*, “Experimental estimation of the delayed neutron fraction β_{eff} of the MAESTRO core in the MINERVE zero power reactor,” *J Nucl Sci Technol*, vol. 52, no. 7–8, pp. 1026–1033, Aug. 2015, doi: 10.1080/00223131.2015.1038331.
- [4] B. Geslot *et al.*, “A pile noise experiment in the reference core of the nuclear research reactor LR-0,” *Ann Nucl Energy*, vol. 189, p. 109833, Sep. 2023, doi: 10.1016/j.anucene.2023.109833.
- [5] R. Boffy, G. Truchet, B. Geslot, G. de Izarra, and A. Sartet, “Measurement of delayed neutrons in a thermal nuclear reactor by means of a long run pile noise experiment in sub-critical state,” *EPJ Web Conf*, vol. 284, p. 15003, May 2023, doi: 10.1051/epjconf/202328415003.
- [6] R. Boffy and et. al, “A pile noise experiment in current mode in the 37 fuel assemblies core configuration of the nuclear research reactor LR-0,” *Submitted to Annals of Nuclear Energy*, 2025.
- [7] B. Geslot, C. Jammes, G. Nolibe, and P. Fougeras, “Multimode Acquisition System Dedicated to Experimental Neutronic Physics,” in *2005 IEEE Instrumentation and Measurement Technology Conference Proceedings*, IEEE, 2005, pp. 1465–1470. doi: 10.1109/IMTC.2005.1604394.
- [8] G. de Izarra *et al.*, “SPECTRON, a neutron noise measurement system in frequency domain,” *Review of Scientific Instruments*, vol. 86, no. 11, p. 115111, Nov. 2015, doi: 10.1063/1.4935250.
- [9] CAEN, “R7771B Neutron Pulse Train Recording Device.” Accessed: May 16, 2025. [Online]. Available: <https://www.caen.it/products/r7771b/>
- [10] Qt Group, “Qt.” Accessed: Jul. 21, 2025. [Online]. Available: <https://www.qt.io/>
- [11] C. E. Cohn, “A Simplified Theory of Pile Noise,” *Nuclear Science and Engineering*, vol. 7, no. 5, pp. 472–475, May 1960, doi: 10.13182/NSE60-4.