

Nuclear heating rate measurement in the MIT research reactor using a new compact CALORRE differential calorimeter

C. Reynard-Carette^{1*}, A. Volte¹, G. Kohse², D. Carpenter², Y. Ostrovsky², M. Ames², S. Hauptman²,
A. Lyoussi³, M. Carette¹

¹Aix Marseille Univ, Université de Toulon, CNRS, IM2NP, Marseille, France

²Massachusetts Institute of Technology, Nuclear Reactor Laboratory, Cambridge, Massachusetts, USA

³CEA/DES/IRENE/DER, Section of Experimental Physics, Safety Tests and Instrumentation, Cadarache, F-13108, Saint Paul-Lez-Durance, France

(*) corresponding author: christelle.carette@univ-amu.fr

Abstract—This paper presents experimental results obtained thanks to a new compact prototype of CALORRE calorimeter during an irradiation campaign inside the MIT Research Reactor (MITR) in October 2024 within the framework of the CALOR-I research program led by Aix-Marseille University and involving the Nuclear Reactor Laboratory of the MIT and the CEA. The nuclear heating rate was measured for the first time in the MITR. An axial mapping of the nuclear heating rate was realized in 15 axial positions of the in-core water-loop of the MITR (B3 position) by moving the CALORRE differential calorimeter while keeping the reactor in operation (at a reactor power equal to 5 MW_{th}) for a stainless steel (ASI 316L) sample. Moreover, the nuclear heating rate was quantified versus the reactor power at a fixed axial position with and without the displacement of the compact CALORRE calorimeter. The sensor reliability and robustness were studied thanks to calibrations conducted before, during and after the irradiation campaign inside the in-core water-loop with the reactor shut down.

Keywords — Calorimetry, Sensor, Irradiation, Mapping, Nuclear heating rate

I. INTRODUCTION

To design and propose innovative nuclear instrumentation, Aix-Marseille University and the CEA as part of the LIMMEX joint laboratory (Laboratory for Instrumentation and Measurement in EXtreme Environments) created in 2010 are conducting several research programs addressing key values for research reactors and tokamaks, such as fast and thermal neutron fluxes, prompt and delayed photon fluxes and intense absorbed dose rates (also called nuclear heating rate). A comprehensive approach was developed particularly regarding heat-flow calorimetric sensors by coupling experimental work with 1-D calculations and 3-D simulations (heat transfer and ray-matter interactions) from non-nuclear laboratory conditions to irradiation campaigns in nuclear environments [1-11]. Two types of calorimeter integrating at least one heating element were patented by AMU and the CEA: one differential calorimeter in 2015 (called CALORRE) [4] and one single-cell

calorimeter in 2020 (called Mono-CALO) [7]. After successful tests of a first prototype of the CALORRE differential calorimeter in the MARIA reactor in November 2015 [9], different challenges associated to this sensor type were and are targeted such as: the extension of the measurement range from very low values for TRIGA reactors such as the JSI TRIGA reactor in Slovenia to high values for MTRs such as the JHR reactor under construction in France, the sensor miniaturization to design a micro-sensor in the future, and the characterization of different materials for fission and/or fusion purposes.

In this context, a research program, called CALOR-I (compact-CALORimeter Irradiations inside the MIT Research Reactor), funded by Aix-Marseille University foundation (A*Midex) and involving the Nuclear Reactor Laboratory of the MIT and the CEA, began in 2020 with four main objectives: (1) the design of a new CALORRE prototype, (2) the study of this prototype from laboratory to irradiation conditions, (3) the axial mapping of an in-core channel of the MIT Research Reactor (MITR) in terms of nuclear heating rate (never measured before), and (4) the comparison of measurement methods and sensors. By taking the feedback from the MARIA campaign into account and carrying out thermal and neutron modeling, a new CALORRE calorimeter prototype of reduced size and similar height to that of the usual single-cell calorimeters was defined and manufactured [9-11].

This paper deals with the experimental study realized on this reduced-size CALORRE prototype inside the in-core water-loop of the MITR in October 2024.

The first part of the paper presents the design of this CALORRE calorimeter with its main features and the calorimeter vehicle placed into the water-loop autoclave and its components. The second part focuses on results obtained during the MITR irradiation campaign. A brief description of the experimental operating protocols is given for the CALORRE calorimeter calibrations and the nuclear heating rate measurements. The axial profile of the nuclear heating rate in the B3 channel is shown for a reactor power of 5 MW_{th}. The measured nuclear heating rate at a specific position as a function of the reactor power is given for two operating protocols. Finally, the reliability and the robustness of the calorimeter is

studied by comparing the calibration curves obtained before, during and after the irradiation campaign with the reactor shut down.

II. CALORIMETER AND EXPERIMENTAL SET-UP

A. CALORRE calorimeter

The new CALORRE prototype corresponds to the most compact CALORRE differential calorimeter built and irradiated to date. This prototype is made of stainless steel (ASI 316L) with a total height equal to 88.5 mm from its nose to its watertight passage and an external diameter of 18 mm (cf. Figure 1). It is composed of two superimposed calorimetric cells with a half-horizontal fin configuration (8 metal sectors and 8 empty sectors each with an equal angle of 22.5°).

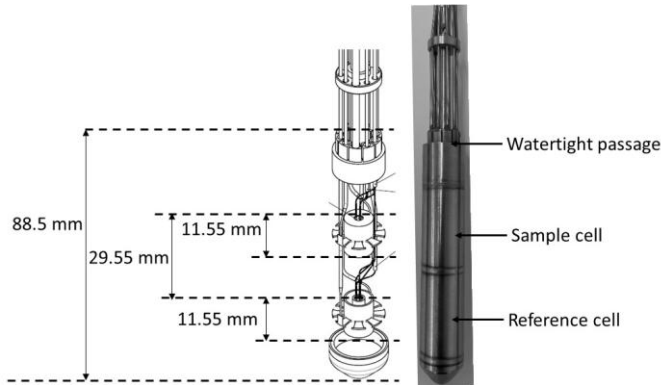

Fig. 1. Schematic diagram and picture of the CALORRE calorimeter

The upper calorimetric cell contains the sample to be characterized. The sample and head structure were manufactured into a single stainless-steel block to avoid additional thermal contact resistance. The lower calorimetric cell, which contains no sample, acts as a reference cell to remove the energy deposition in areas of the sample cell not corresponding to the sample. Each cell includes two K-type thermocouples and a heating element (4-wire made of Nickel-Chromium). Each calorimetric cell has a height equal to 11.55 mm with an external vertical fin of 31.55 mm in height and 18 mm in external diameter serving as sensor envelope by welding. The watertight assembly of the calorimeter has an inter-cell spacing of 18 mm and an inter-sample area spacing of 29.55 mm. The calorimeter is filled with N_2 .

B. Experimental set-up

The experimental set-up is composed of several components (cf. Figure 2):

- the CALORRE calorimeter and a gamma thermometer
- a K-type thermocouple to measure the temperature in the water-loop close to the CALORRE calorimeter
- mechanical elements to center the calorimeter vehicle in the channel, displace it, impose a fluid flow temperature in the loop, to watertight (centering fixture, sensor tube, water inlet and outlet pipes, autoclave flange with dynamic seal for sensor tube and its displacement)
- a displacement system to change the axial position of the calorimeter
- a programmable power supply for the calibration of each CALORRE calorimetric cell

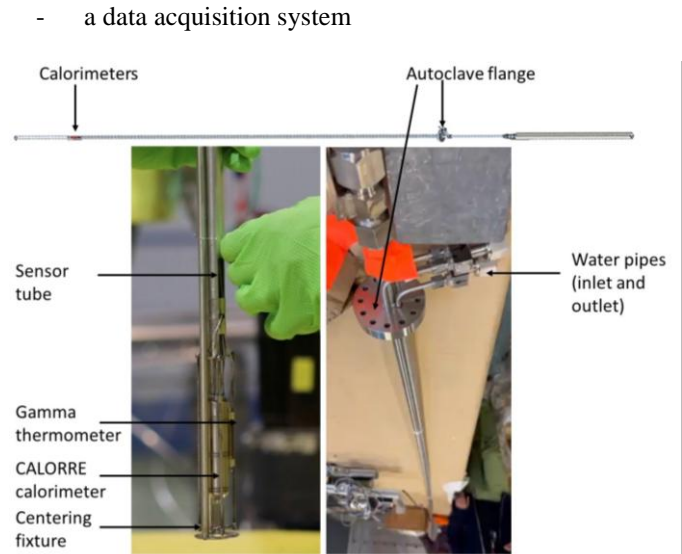

Fig. 2. Schematic diagram and two pictures of the calorimeter vehicle

III. EXPERIMENTAL RESULTS

A. Axial mapping of the nuclear heating rate

The axial profile of the nuclear heating rate was obtained by moving the CALORRE calorimeter with the reactor operating at a power of 5 MW_{th} and a water-loop temperature of approximately 120°C .

For each axial position z_i , the measurement was realized in two steps. In step a), the calorimeter is placed at the axial position z_i and the steady temperatures of the two cells are measured. In step b), the calorimeter is moved 29.55 mm upward to place the reference cell at the same axial position z_i as that of the sample cell in step a), and the steady temperatures of the two cells are measured. This protocol was repeated to determine the axial profile in 15 positions of the sample between -109.38 mm and $+304.32 \text{ mm}$ (cf. Figure 3).

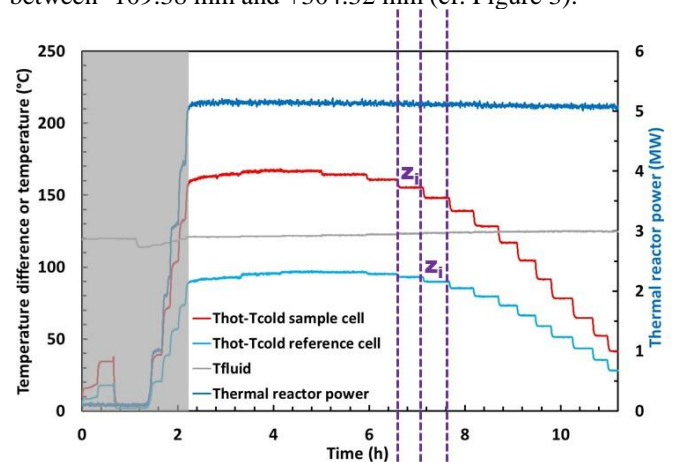

Fig. 3. Temperature differences of the CALORRE calorimetric cells, water-loop temperature and reactor power versus time for various axial positions in B3 channel of the MITR

The nuclear heating rate is calculated for each axial position z_i thanks to the two differences of steady temperatures obtained for the sample cell at the step a) and for the reference cell at step b) respectively, and by considering the calibration curves (cf. section III.C).

The axial profile is given in Figure 4 (in order to take the reactor power variation into account during the experiments, the nuclear heating rate was set to a reactor power of 5 MW_{th} whatever the axial position). The maximum value of the nuclear heating rate in stainless steel is equal to 2.04 W.g⁻¹ at -79.83 mm.

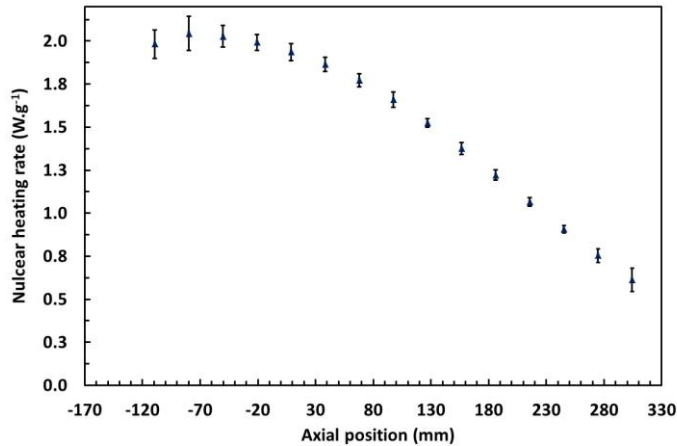

Fig. 4. Axial profile of the nuclear heating rate in B3 channel of the MITR for a power of 5 MW_{th}

B. Nuclear heating rate versus the reactor power

The nuclear heating rate measurement versus the reactor power was quantified over several days of the irradiation campaign for a specific position of the sample (-50.28 mm). The results are given in Figure 5 for two operating protocols (with or without CALORRE displacement).

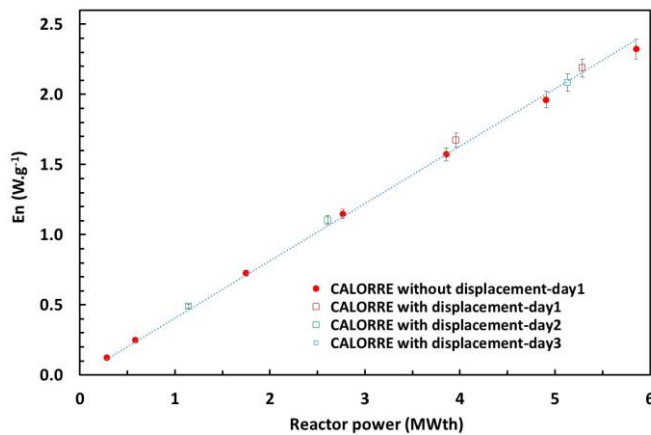

Fig. 5. Nuclear heating rate versus the reactor power at -50.28 mm (sample median plane) with or without moving the calorimeter

The empty symbols correspond to results obtained with the same operating protocol described in the previous section. The nuclear heating rate is determined by moving the calorimeter to consider the temperature differences of the two cells at the same axial position.

The solid symbols are obtained without moving the calorimeter and thus by using the temperature differences of the two superimposed cells not located at the same axial position. That is possible to apply this method without displacement because the discrepancy of the nuclear heating rate between these two protocols at -50.28 mm is very low (0.2 %) due to the reduced size of the calorimeter and the low flux gradient in this area (a study with and without moving CALORRE calorimeter

was realized during the axial mapping, these results are not presented in this paper).

The nuclear heating rate was measured versus the reactor power from 284 kW_{th} to 5.9 MW_{th} and it is between 0.13 W.g⁻¹ and 2.32 W.g⁻¹. A good reproducibility was observed.

C. Reliability of the calorimeter

Another objective of the irradiation campaign was to verify the reliability and robustness of the CALORRE calorimeter by carrying out calibrations of the CALORRE calorimetric cells while the reactor was shut down at different times during the irradiation campaign. They were performed in the night before, after and during the irradiation campaign with reproducibility tests.

In that case, the calorimeter was placed in a fixed position in the upper part of the channel to avoid residual power after the reactor shut down: bottom of the CALORRE calorimeter at +355.4 mm. To calibrate each calorimetric cell, the nuclear heating rate is simulated by generating heat by means of Joule effect thanks to the heating element integrated into each cell. Increments of electrical current were injected successively into each heating element until a stable thermal state was reached for each increment (cf. Figure 6). Different water-loop temperatures were tested. The water-loop temperature for the first calibration realized in the reactor before the start of the irradiation campaign was set to 75 °C but as it was not possible to reach this value with the reactor in operation at 5 MW_{th}, new higher water-loop temperature values were used for the next calibrations: 115 °C and 120 °C.

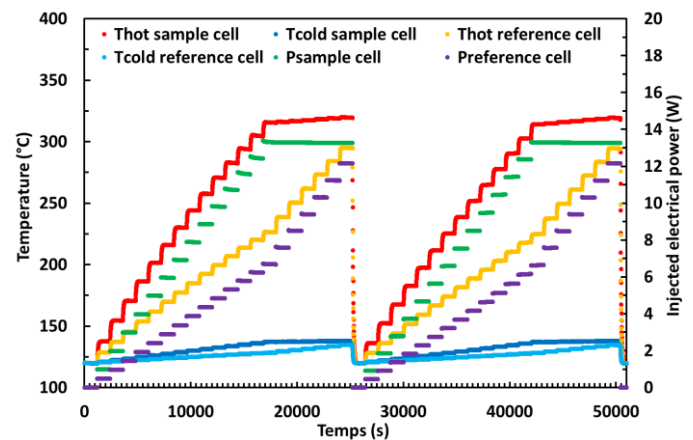

Fig. 6. Temporal response curves in temperature and injected electrical power for two successive calibrations of the two CALORRE calorimetric cells after the irradiation campaign with reactor shut down

Figure 6 shows an example of temporal curves in temperatures and injected electrical power for two calibrations realized successively (reproducibility tests) after the irradiation campaign with reactor shut down, for an imposed water-loop temperature equal to 120 °C and an electrical power range up to 13.3 W.

Figure 7 presents the results obtained for the different experimental conditions and reproducibility tests. The calibration curves obtained for the two calorimetric cells with an imposed water-loop temperature close to that reached when the reactor was in operation, have very low drift demonstrating the reliability and robustness of the CALORRE calorimeter.

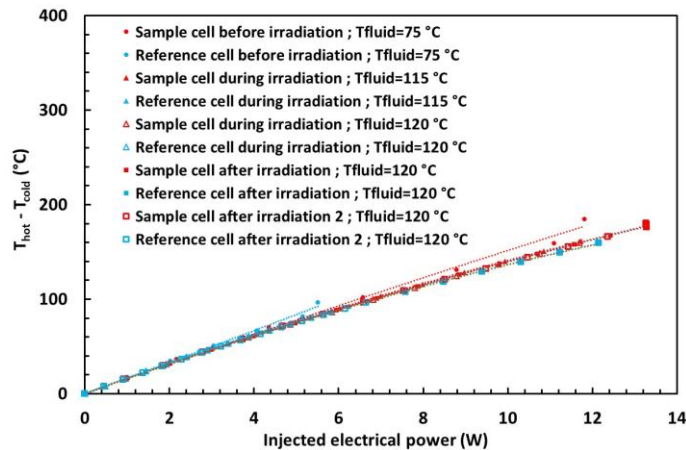

Fig. 7. Calibration curves of the two CALORRE calorimetric cells at different times during the irradiation campaign with reactor shut down

IV. CONCLUSIONS

The most compact prototype of the CALORRE differential calorimeter to date, with a height of 88.5 mm, was studied thanks to an irradiation campaign in the in-core water-loop in the B3 position of the MITR.

The CALORRE sensor allowed the quantification of the nuclear heating rate for the first time in the MITR. The measurements were realized for a sample made of stainless steel (ASI 316L) for different experimental conditions and operating protocols. A maximum nuclear heating rate of $2.04 \text{ W}\cdot\text{g}^{-1}$ were obtained at 5 MW_{th} .

An axial profile of the nuclear heating rate was determined in 15 positions of the sample between -109.38 mm and $+304.32 \text{ mm}$ by moving the calorimeter with an increment of 29.55 mm while keeping the reactor in operation at 5 MW_{th} and thus by considering the temperature differences of the two superimposed calorimetric cells for the same axial position.

The influence of the size of this compact CALORRE calorimeter on the nuclear heating rate quantification was estimated by using the responses of the two calorimetric cells without calorimeter displacement. A low influence was observed in the zone from -109 mm to $+38.37 \text{ mm}$.

The nuclear heating rate was measured at -50.28 mm versus the reactor power: between $0.13 \text{ W}\cdot\text{g}^{-1}$ and $2.32 \text{ W}\cdot\text{g}^{-1}$ from $284 \text{ kW}_{\text{th}}$ to $5.9 \text{ MW}_{\text{th}}$ respectively.

The reliability and the robustness of the calorimeter was verified thanks to different calibrations before, during and after the irradiation campaign with the reactor shut down.

Other experiments during this successful irradiation campaign in the MITR were conducted (and not presented in this paper) with the CALORRE calorimeter (axial profile with a higher space-resolution in a specific area, another measurement method by using one heater, reproducibility, residual power measurement...) and with the gamma thermometer. The corresponding data are currently being processed. After analyzing the experimental data, 3-D simulations will be performed taking the entire system into account in order to make future comparisons.

V. ACKNOWLEDGEMENTS

The CALOR-I project leading to this publication has received funding from the Excellence Initiative of Aix-

Marseille University - A*Midex, a French “Investissements d’Avenir” programme”, AMX-19-IET-013.

REFERENCES

- [1] A. Lyoussi, D. Fourmentel, J-F. Villard, J-Y. Malo, P.Guimbal, H. Carcreff, C. Gonnier, G. Bignan, J-P. Chauvin, C. Reynard-Carette, J. Brun, O. Merroun, M. Carette, M. Muraglia, A. Janulyte, Y. Zerega and J. Andre, “Advanced methodology and instrumentation for accurate on line measurements of neutron, photon and nuclear heating parameters inside Jules Horowitz MTR Reactor”, Proceedings of Conferences RRFM and IGORR 2012, pp. 21-25, Prague, Czech Republic, 18-22 March 2012.
- [2] C. Reynard-Carette, G. Kohse, J. Brun, M. Carette, A. Volte, A. Lyoussi, “Review of nuclear heating measurement by calorimetry in France and USA”, Proc. ANIMMA 2017, Jun. 2017, EPJ Web of Conferences 170, 04019 (2018).
- [3] J. Brun, C. Reynard-Carette, A. Lyoussi, C. De Vita, M. Carette, M. Muraglia, D. Fourmentel, P. Guimbal, J.-F. Villard, “Comparison of the thermal calibration response of two calorimetric cells dedicated to nuclear heating measurements”, IEEE Trans. Nucl. Sci., vol. 61, no. 4, pp. 2254-2261, Aug. 2014.
- [4] M. Carette, A. Lyoussi, J. Brun, C. Reynard-Carette, J.F. Villard, « Epreuve pour mesure d'échauffements nucléaire dans un réacteur nucléaire, et cellule calorimétrique comprenant au moins une telle éprouvette », FR1553136A, 2015-04-10.
- [5] A. Volte, C. Reynard-Carette, A. Lyoussi, J. Brun, M. Carette, "Study of the Response of a New Compact Calorimetric Cell for Nuclear Heating Rate Measurements", IEEE Trans. Nucl. Sci., vol. 65, no. 9, pp. 2461-2470, Sept. 2018.
- [6] A. Volte, J. Brun, A. Lyoussi, M. Carette, C. Reynard-Carette, “Qualification of a New Differential Calorimeter Configuration Dedicated to Nuclear Heating Rates up to $20 \text{ W}\cdot\text{g}^{-1}$ ”, IEEE Trans. Nucl. Sci., vol. 67, no. 11, pp. 2405-2414, Nov. 2020.
- [7] C. Reynard-Carette, A. Volte, A. Lyoussi, M. Carette, « Noyau de mesure pour la mesure d'échauffement nucléaire en réacteur nucléaire et capteur calorimétrique intégrant un tel noyau de mesure », Patent 21212899.5, 2021-12-07.
- [8] J. Rebaud, A. Volte, M. Carette, A. Lyoussi, C. Reynard-Carette, “Experimental and numerical results for a new single-cell calorimeter dedicated to nuclear heating rate measurement”, ANIMMA 2023, 12-16 June 2023, Lucca, Italy, EPJ Web of Conferences 288, 04008 (2023), <https://doi.org/10.1051/epjconf/202328804008>.
- [9] A. Volte, M. Carette, A. Lyoussi, G. Kohse, J. Rebaud, V. Valero, C. Reynard-Carette, “Review of CALORRE Calorimeter Characterizations Under Laboratory and Irradiation Conditions”, IEEE Trans. Nucl. Sci., vol. 69, no. 4, pp. 840-848, April 2022, doi: 10.1109/TNS.2022.3150148.
- [10] S. Hauptman, A. Volte, G. Kohse, M. Carette, A. Lyoussi, C. Reynard-Carette, “Flux and Nuclear Heating Rate Calculations for CALORRE Irradiation in MITR”, ANIMMA 2023, 12-16 June 2023, Lucca, Italy., EPJ Web of Conferences 288, 04010 (2023), <https://doi.org/10.1051/epjconf/202328804010>.
- [11] A. Volte, S. Hauptman, D. Carpenter, M. Carette, A. Lyoussi, G. Kohse, C. Reynard-Carette, “Numerical and Experimental Characterization of a New Reduced-Height CALORRE Differential Calorimeter for CALOR-I Irradiation in MITR”, in IEEE Trans-actions on Nuclear Science, vol. 71, no. 5, pp. 1134-1143, May 2024, doi: 10.1109/TNS.2024.3388518.