

# $\delta^{13}\text{C}$ carbon isotopic composition of $\text{CO}_2$ in the atmosphere by Lidar

Fabien Gibert<sup>(a)</sup>, Dimitri Edouart<sup>(a)</sup>, Claire Cénac<sup>(a)</sup>

<sup>(a)</sup> Laboratoire de Météorologie Dynamique (LMD/IPSL), École polytechnique, Institut polytechnique de Paris, Sorbonne Université, École normale supérieure, PSL Research University, CNRS, École des Ponts, Palaiseau, France, E-mail : [gibert@lmd.polytechnique.fr](mailto:gibert@lmd.polytechnique.fr)

**Abstract:** A differential absorption lidar (DIAL) has been developed at LMD to measure the variation of stable isotopic composition of  $\text{CO}_2$ ,  $\delta^{13}\text{C}$ , in the atmosphere. The lidar uses a new 3-wavelengths single mode hybrid fiber/bulk pulsed laser at  $2\ \mu\text{m}$  and a coherent detection. We present the geophysical objectives of this work, the expected performances and the experimental set-up. Preliminary atmospheric results will be discussed at the conference.

## 1. Introduction

$\text{CO}_2$  is the main anthropogenic greenhouse gas responsible for the current global warming. In 2024, its concentration is larger than 410 ppm, a level never reached over the last 2 millions of years with devastating consequences for present and future life on planet Earth. In our understanding of carbon cycle, the biospheric sink remains very complex to assess at regional scale given the strong ecosystem space and time heterogeneity [1].

The  $\text{CO}_2$  stable isotopic fraction  $\delta^{13}\text{C}$  is an interesting tracer for  $\text{CO}_2$  surface-atmosphere exchanges at local scale. It enables to characterize plant/ soil physiological processes (photosynthesis, respiration, decomposition of organic matter) and to issue a diagnosis on sources (anthropogenic, geological) and sinks (biosphere, ocean) of  $\text{CO}_2$ . In addition,  $\delta^{13}\text{C}$  may help to discriminate type of plant ( $\text{C}_3$  or  $\text{C}_4$ ) and ecosystems that contribute the most to biosphere  $\text{CO}_2$  uptake and their evolution with warming conditions [2].

Compared to former complex mass spectrometry systems [3], tunable diode laser absorption [4] or recent cavity ring down spectroscopy [5] offer interesting ways to make in situ measurements in the atmosphere. To increase the spatial scale representativity of in situ measurement, an integrated path differential absorption (IPDA) lidar concept at  $4.4\ \mu\text{m}$  has been studied [6]. Although such system seems to reach similar precision on  $\delta^{13}\text{C}$  ( $< 0.2\ \text{‰}$ ) than in situ sensor, the horizontal

profiling of  $\delta^{13}\text{C}$  by Lidar will bring outstanding information on sources/sinks pattern and origin. Even the vertical profiling will help to characterize the local/ long distance transport of  $\text{CO}_2$ .

In this framework, a new three wavelengths differential absorption Lidar (DIAL) at  $2\ \mu\text{m}$  has been considered and recently developed at LMD to measure simultaneously  $^{12}\text{CO}_2$  and  $^{13}\text{CO}_2$  absorption. The Lidar relies on a new hybrid fibered/bulk laser source and a coherent detection.

## 2. Methodology and required precision on $\delta^{13}\text{C}$

The natural standard abundance of  $^{12}\text{CO}_2$  and  $^{13}\text{CO}_2$  in the atmosphere are 98.9% and 1.1% respectively. The variation of isotopic ratio is measured with respect to a reference, the Vienna Pee Dee Belemnite (VPDB) isotopic ratio:

$$\delta^{13}\text{C} = \left[ \frac{\left( \frac{^{13}\text{C}}{^{12}\text{C}} \right)_{meas.}}{\left( \frac{^{13}\text{C}}{^{12}\text{C}} \right)_{VPDB}} - 1 \right] \times 1000 \quad (1)$$

where  $^{12}\text{C}$  is taken as the  $^{12}\text{CO}_2$  mixing ratio in the atmosphere.

The natural variation of  $\delta^{13}\text{C}$  spreads over a scale of 100 ‰:  $\sim +5\text{‰}$  for carbonate-gas  $\text{CO}_2$  equilibrium in air-sea /geological water exchanges,  $-7\text{‰}$  for standard  $\text{CO}_2$  in the atmosphere,  $\sim -13\text{‰}$  for  $\text{C}_4$  plant – air exchanges but  $\sim -25\text{‰}$  for  $\text{C}_3$  plant that is similar

to fossil fuel emission (coal and oil) whereas the lowest  $\delta^{13}\text{C}$  value,  $\sim -35\%$ , can be found in natural gas emission. Then, a reasonable precision of 10‰ (5‰ ideally) for  $\delta^{13}\text{C}$  and then for  $^{12}\text{CO}_2$  and  $^{13}\text{CO}_2$  mixing ratio or absorption DIAL measurements is required as a basis to obtain some useful information on  $\text{CO}_2$  surface-atmosphere exchanges.

### 3. Spectroscopy in the 2 $\mu\text{m}$ band and consequences for $^{13}\text{CO}_2$ DIAL measurement

The 2.05  $\mu\text{m}$   $\text{CO}_2$  absorption band has already been used at LMD to make horizontal  $\text{CO}_2$  profiles in the atmospheric boundary layer with a coherent DIAL (CDIAL) [7]. The instrument was able to make a 150 m-15 min  $^{12}\text{CO}_2$  mixing ratio measurement with a precision of 0.5% at 500 m which agrees with our  $\delta^{13}\text{C}$  precision requirement. However, the  $^{13}\text{CO}_2$  absorption line intensities are usually far lower by two orders of magnitude (following the isotopic ratio) than the  $^{12}\text{CO}_2$  lines. This entails a differential optical depth far lower than 1 for a range gate of 100 m, which reduces significantly the DIAL precision [8]. Fortunately, in the 2.05 band, the  $^{13}\text{CO}_2$  line intensities and then absorption cross sections (ACS) are larger by one order of magnitude as seen in Figure 1. ACS are computed using the radiative transfer code STRANSAC and the spectroscopic database GEISA.

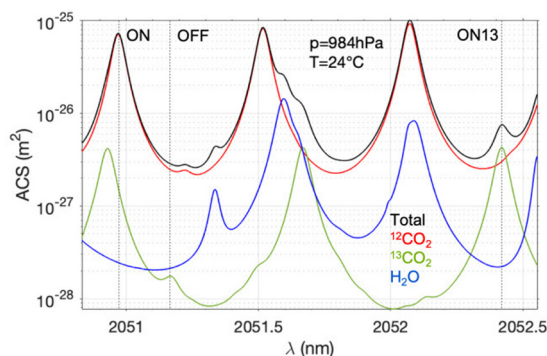

Figure 1. Absorption cross-section (ACS) for  $^{12}\text{CO}_2$ ,  $^{13}\text{CO}_2$  and  $\text{H}_2\text{O}$  for pressure 984 hPa and temperature 24°C.  $\text{H}_2\text{O}$  ACS have been multiplied by a factor of 25 with respect to mixing ratios in the atmosphere ( $\text{CO}_2$ : 0.04%,  $\text{H}_2\text{O}$ : 1%).  $^{13}\text{CO}_2$  ACS is multiplied by the VPDB isotopic ratio. The DIAL wavelengths for OFF, ON and ON13 positions are indicated.

Using Figure 1, we are able to calculate absorption coefficient for the  $^{12}\text{CO}_2$  and  $^{13}\text{CO}_2$

lines considered in this work (ON and ON13 wavelengths):  $0.749 \text{ km}^{-1}$  and  $0.057 \text{ km}^{-1}$  respectively. Therefore, to obtain the same precision as for DIAL  $^{12}\text{CO}_2$  measurement, the  $^{13}\text{CO}_2$  signal to noise ratio (SNR) must be increased by a factor of roughly 13, that's to say a larger number of shot-pair averaging by a factor of roughly 171 must be used. Comparing to Gibert et al. (2015) set-up [7], range and time resolution will have then to be reduced and the laser should run at higher pulse repetition frequency.

### 4. Instrumental set-up

The lidar set-up is displayed in Figure 2. The laser set-up has been significantly modified following recent work on hybrid fiber/bulk amplifier in the 2  $\mu\text{m}$  domain [9].

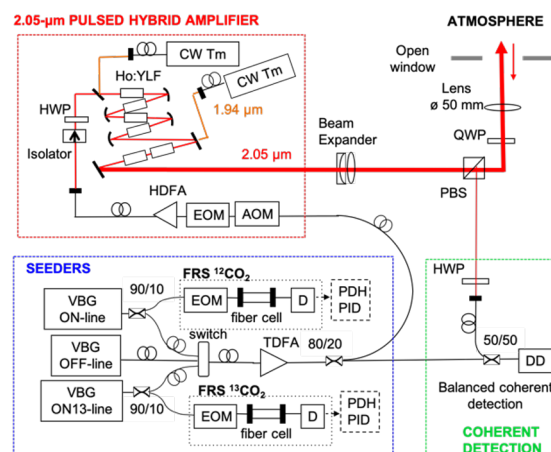

Figure 2. DIAL set-up for  $\delta^{13}\text{C}$  measurement. FRS : frequency reference system, EOM et AOM : electro and acoustic-optical modulators, HDFA and TDFA : Holmium and Thulium fiber amplifiers, VBG :volume Bragg grated laser diode, PDH : Pound-Drever-Hall, HWP and QWP :half and quarter wave plate, PBS : polarizer beam splitter.

The emitter uses a seeder module with three narrow linewidth external cavity laser diodes (special model CHEETAH from Sacher Lasertechnik). Both ON and ON13 seeders are locked to  $^{12}\text{CO}_2$  and  $^{13}\text{CO}_2$  absorption line centers using a FRS with low pressured gas cell and a PDH technique. After a 4x1 fibered switch, the seeder power is amplified through a TDFA continuous wave amplifier (model CTFA from Keopsys). The laser pulses are then built using AOM and EOM optical modulators. A custom Holmium pulsed fibered amplifier (model THALYS-2051nm-0.2W from Cybel)

enables to deliver a maximum of 17 W peak power ( $\sim 3.5 \mu\text{J}$  @ 200 ns) without parasitic stimulated Brillouin scattering (SBS) signal. The laser pulses are then amplified in a free space multi-pass Ho:YLF amplifier. Six 0.5%-Holmium doped 50-mm long Ho:YLF rods pumped by two 50-W linearly polarized Thulium fiber lasers (model TLR-50-1940-LP from IPG Photonics) are used to obtain a mean 50 W output power at  $2.05 \mu\text{m}$  ( $5 \text{ mJ}$  @ 10 kHz). This laser architecture enables flexible characteristics of the laser: pulse duration and energy, PRF and especially the choice to have a larger number of shots for  $^{13}\text{CO}_2$  measurements as mentioned above. A coherent detection with a balanced InGaAs photodiode detection (Discovery Semiconductors) and a four channels data acquisition and real time signal processing system (model Waverider-250 from LICEL) completes the set-up.

## 5. Current and future work

The lidar set-up has been achieved and is then ready for atmospheric tests. First results will be presented at the conference.

## 6. References

- [1] Friedlingstein et al. : “Global Carbon Budget 2020”, *Earth Syst. Sci. Data*, **12**, 3269-3340, (2020).
- [2] W.G. Mook, M. Koopmans, A.F. Carter and C.D. Keeling: “Seasonal, latitudinal, and secular variations in the abundance and isotopic ratios of atmospheric carbon dioxide: 1. Results from land stations”. *Journal of geophysical research-Oceans and atmospheres*, **88**(NC15), 915-933, (2014).
- [3] J. Li et al. “Quantitative measurement of carbon isotopic composition in  $\text{CO}_2$  gas reservoir by micro-laser Raman spectroscopy”, *Spectrochim. Acta A, Mol. Biomol. Spectrosc.*, **195**, 191-198, (2018).
- [4] D.T. Cassidy and J. Reid, “Atmospheric pressure monitoring of trace gases using tunable diode lasers”, *Appl. Opt.*, **21**(7), 1185-1190, (1982).
- [5] Y.-C. Lin et al., “Development of a monitoring system for semicontinuous measurements of stable carbon isotope ratios in atmospheric carbonaceous aerosols: Optimized methods and application to field measurements”, *Anal. Chem.*, **92**(21), 14373-14382, (2020)
- [6] T. Shi, G. Han, X. Ma, W. Gong, Z. Pei, H. Xu, R. Qiu, H. Zhang and J. Zhang, “Potential of ground-based multiwavelength differential absorption lidar to measure  $\delta^{13}\text{C}$  in open detected path”, *IEEE Geoscienc and remote sensing letters*, **19**, 7003204, (2022)
- [7] F. Gibert, D. Edouart, C; Cénac, F. le Mounier and A. Dumas, “2- $\mu\text{m}$  Ho emitter-based coherent DIAL for  $\text{CO}_2$  profiling in the atmosphere”, **40** (13), 3093-3096, (2015)
- [8] D. Bruneau, F. Gibert, P. Flamant and J. Pelon, “Complementary study of differential absorption lidar optimization in direct and heterodyne detections”, *Appl. Opt.*, **45** (20), 4898-4908, (2006).
- [9] J. Lahyani, M. Thiers, F. Gibert, D; Edouart, J. Le Gouët and N. Cézard, “Hybrid fiber/bulk laser source designed for  $\text{CO}_2$  and wind measurements at  $2.05 \mu\text{m}$ ”, *Opt. Lett.*, **49** (4), 969-972, (2024)