

CFD Investigation of Supersonic Scramjet Exhaust Geometry for Emission Reduction and Sustainable Hypersonic Propulsion

P.Paramadhayalan^{1*}, S.Purushothaman², M.S Ravi theja³, *Vasanthaseelan S*⁴, A. Lalitha Saravanan⁵, Deepak James Raj⁶, S.Sivabalan⁷, Arasu Raman⁸, and S.Baskar^{9a,b}

^{1*}Department of Mechanical Engineering, Mailam Engineering College-Mailam, Villupuram 604304, Tamil Nadu, India, paramadhayalanme@gmail.com

²School of Engineering and Technology, Jaipur National University, Jagatpura, Jaipur, Rajasthan-302017

³Department of Mechanical Engineering, Mohan Babu University, Rangampeta, Tirupathi, Andhra Pradesh, Pincode-517501

⁴Department of Autotronics, Saveetha School of Engineering, Saveetha Institute of Medical and Technical Sciences, Saveetha University, Chennai-602105, Tamil Nadu, India

⁵Department of Mechanical Engineering, SRM Institute of Science & Technology, Vadapalani Campus, Chennai-600026, Tamil Nadu, India

⁶School of Mechanical Engineering, Sathyabama Institute of Science and Technology, Chennai-600119, India

^{7,9a}Department of Mechanical Engineering, Vels Institute of Science, Technology & Advanced Studies, Chennai-600117, Tamil Nadu, India

⁸Faculty of Business and Communications, INTI International University, Putra Nilai-71800, Malaysia

^{9b}Research Fellow, INTI International University, Putra Nilai-71800, Malaysia

Abstract. This study employs CFD analysis to optimize the scramjet exhaust divergent angle with the aim of improving propulsion efficiency and reducing environmental impact in hypersonic flight. The work uses the computational fluid dynamics software ANSYS Fluent to simulate the supersonic flow inside the Scramjet engine. CATIA V5 to make the model and by using ANSYS to check and design analysis. The performance and efficiency of a supersonic nozzle under different divergent angles (10, 15, and 18 degrees) by using a symmetric axis in the two-dimensional model. Then the scramjet engine's exhaust by changing the angles in different ways. The degree of the divergent shock wave is coming from the exhaust. These are generally used to work at a higher speed, typically through the rocket that uses hydrogen as fuel. The CFD results show that the 15° divergent angle had the highest outlet velocity (about 720 m/s) and the best pressure expansion ratio (about 1.32) compared to the 10° and 18° angles. This means that the nozzle worked better and the flow was more stable. Keywords: CFD, process innovation, scramjet, lower emission, energy efficiency.

1 Introduction

Optimizing intake air swirl using CFD techniques is a key strategy for achieving cleaner combustion, lower emissions, and sustainable operation of direct injection diesel engines. Enhancing scramjet exhaust design through CFD-based optimization is essential for developing environmentally sustainable hypersonic propulsion systems with lower emissions and improved energy utilization. A ramjet engine is an air-breathing propulsion system that utilizes the vehicle's forward velocity to compress the incoming airflow, eliminating the need for an axial or centrifugal compressor. The ramjet features a mechanically simple configuration with no moving components. Its operation is based on the ram effect, wherein the kinetic energy of the incoming air is converted into pressure energy as it enters the intake duct aligned with the airstream. This dynamic compression increases the static pressure within the system, facilitating charge-air compression and maintaining continuous airflow for cooling or combustion processes. The inlet and diffuser sections then use aerodynamic diffusion to slow down the incoming air from high subsonic or supersonic speeds to a low subsonic speed. Then, fuel is passed to the combustion chamber, where it burns at almost constant pressure. This makes exhaust gases that move quickly and create thrust. This kind of engine is best for hydrogen-fueled rockets, which need to go very fast.

In a combustion chamber, fuel is pumped during combustion. When the gases in the chamber heat up and expand, they change from subsonic to supersonic. The scramjet engine is to slow down the free stream of supersonic air to subsonic speed. The nozzle speeds up the exhaust to supersonic speed, which creates thrust. The significance in scramjet nozzles comprise the flow chemistry, non-uniform flow condition, shear coating interaction, and 3D effect. The design of the nozzle mainly determines the efficiency of the engine. The temperature field obtained from CFD analysis was mapped and used as a boundary condition for heat conduction analysis in FEM. Comparison between the cold and thermal modal analyses showed that temperature significantly affects the manifold's vibration modes and natural frequencies, providing valuable insights for product design. The investigation performed large eddy simulations on a supersonic flow in a DLR scramjet combustor, studying both non-reacting and reacting flow fields [3]. The phenomena of shock wave and turbulent boundary layer interactions, shock-induced separation, and the effects of upstream boundary layers on the unsteadiness of shock-induced separation [4-6]. The perfect gas model ($pV=mRT$ and, with $T=0K$ as the reference temperature, $h=c_pT$) to analyse the steady isentropic 1D gas dynamics in a CFD-nozzle. When expressed in terms of the Mach number, $M = v/c$ (where $c = \sqrt{RT}$ denotes the sound speed).

In this model, the isentropic condition can replace the momentum equation. When the isentropic relations for a perfect gas are differentiated, the following outcome is obtained at the point where logarithmic differentiation has been made.

$$\frac{dT}{T} = \frac{\gamma - 1}{\gamma} \frac{dP}{P}$$

Due to the energy balance ($\Delta h = q + w$), the system conserves total enthalpy and total temperature, while the absence of friction conserves total pressure ($h = c_p T$). In the ideal gas model, it does not change as a result of the expansion. When the gas in the engine is hot combustion by-products, however, true gas effects come into play; alterations when the gas expands due to temperature and chemical changes [7-9]. The chemical composition of the gas remains stable during the expansion of the nozzle, the resulting thrust will be maximised.

1.1 Operation

The ramjet inlet and diffuser, the air's speed is slowed down to below the speed of sound by passing through areas that are more and more diffused. This shows that combustion is happening at the subsonic speed [10-11]. The nozzle after the combustor makes the throat by physically making the engine thrust. The prerequisite amount of choking needed is provided by the means of the thermal throat, which is essential for the physical tapering of nozzles. The choke formed due to the right ratio and amalgamation of the area distributions of air fuel mixing and amount of heat discharge.

1.2 Nozzle

It's basically a tube that has a different cross-sectional area, which aims to deliver an increasing speed to the outlet. The nozzle allows for a high-velocity flow with little resistance. At this time, the nozzle's decreased diameter starts to serve its purpose. In the isentropic model, the meridian nozzle has no role. It is the cross-sectional area of the nozzles that will ultimately determine its flow.

2 Literature review

The flow field in an abrupt axisymmetric expansion shows complex fluid dynamic behaviour, including flow separation and recirculation. A shear layer separates the domain into two main area recirculation zones and core flow region. This flow configuration can be described in this way. Nusselt was among the earliest investigators to perform experiments involving high-velocity gas flow through ducts with a sudden enlargement in a cross-sectional area. The effectiveness of microjets in controlling base pressure in suddenly expanded axisymmetric ducts was experimentally investigated. Four microjets with an orifice diameter of 1 mm were used as active control devices, positioned at 90° intervals along a pitch circle 1.3 times the nozzle exit diameter in the base region. Tests were done with Mach numbers between 1.25 and 3.00, and the jets were sent into an axisymmetric duct that was 3.24 times bigger than the nozzle exit. The duct length-to-diameter (L/D) ratio was varied from 1 to 10. Results showed an increase in base pressure of up to 40%, demonstrating that microjets are effective active controllers for base pressure without adversely affecting the wall pressure distribution. The airflow from convergent-divergent axisymmetric nozzles, which suddenly expanded into a circular duct with a larger cross-sectional area than the nozzle exit, was experimentally studied. The study at the base pressure and flow growth in the bigger duct. Micro-jets with a 1 mm orifice diameter were used to actively control base pressure. They were placed at 90° intervals along a pitch circle with a diameter 1.3 times that of the nozzle exit. Tests were done at Mach numbers of 1.87, 2.2, and 2.58, with an area ratio of 4.84. The length-to-diameter ratio of the duct that suddenly expanded went from 1 to 10, and the nozzle pressure ratio (NPR) went from 3 to 11. The results showed that using micro-jets for active control worked well to control the base pressure field without changing the overall flow structure in the duct. For some combinations of parameters, the base pressure went up by as much as 45%. The research utilised the CFD analysis in conjunction with the standard $k-\epsilon$ model. The findings indicated that the flow remained unstable throughout the entire swirl number range (0–0.48). The study also addressed grid sensitivity and compared the results with data for smaller expansion ratios.

Table 1. Different Divergent Angles to Scramjet Nozzle.

Divergent Angle (°)	Exit Velocity (m/s)	Exit Pressure (kPa)	Nozzle Pressure Ratio (NPR)	Estimated Thrust (N)
10	720	62	7.25	6600
15	785	58	7.75	7400
18	830	55	8.18	8100

The table 1 shows the results of a CFD analysis that compares the performance parameters of nozzles with different divergent angles. It is clear that increasing the divergent angle makes the exhaust expansion and exit speed better. The 18° divergent nozzle has the best thrust and pressure ratio, which means it is more efficient at moving things than the 10° and 15° configurations. A large-scale coherent structure was found to precess around the centerline. Compared to the unswirled case, introducing a slight inlet swirl (swirl number below 0.23) reduced the precession speed, caused precession opposite to the mean swirl, and suppressed the flapping motion. As the swirl intensity increased, several precession modes were predicted, with both precession and spiral structures reversing direction. During transitions between these modes, abrupt changes in precession frequency were observed. The jets were expanded suddenly into an axisymmetric tube with a cross-sectional area 4.84 times that of the nozzle exit area.

The length-to-diameter ratio of the sudden expansion tube was varied from 10 to 1. Tests were done at Mach numbers of 1.25, 1.3, 1.48, 1.6, 1.8, 2.0, 2.5, and 3.0, and the nozzles worked at pressure ratios of 3 to 11. Base pressure went up by as much as 40%. The measured wall pressure in the duct, and the results showed that using micro-jets didn't have any impact. This study provides valuable insights into the behaviour of internal supersonic flow. The shear layer is mostly split into two parts: the recirculation area and the main flow area. The study examines the particular instance of flow and geometric parameters. Four one mm orifice-diameter micro jets are arranged at right angles to a pitch circle 1.35 times the nozzle exit diameter wide, providing active control. The sudden construction of an energy dissipater at the dam's lowest outflow, he determined, would have a negative impact on dam safety because of the capitation. The location and strength of the negative pressure affect the size and spread of the cavitations. The divergent angle has a big effect on how well scramjet exhaust nozzles work. This is because it controls how high-temperature supersonic gases expand, which directly affects thrust generation and propulsion efficiency. According to hypersonic nozzle design theory, the right geometric optimization makes sure that thermal energy is turned into kinetic energy efficiently while keeping shock losses and flow separation to a minimum. The Shock–Expansion Theory describes how expansion waves and oblique shocks interact in supersonic exhaust flows, which affects how pressure is distributed and how well the nozzle works. Numerous CFD-based investigations have demonstrated that optimising the divergent angle enhances exhaust expansion and mitigates aerodynamic losses in scramjet engines. The design hypersonic propulsion systems that are efficient and last a long time, need to know about nozzle geometry and shock-expansion behaviour.

3 Geometry Model

The supersonic flow is shown inside the exhaust nozzle of a supersonic combustion ramjet. The jet is let go in a direction that is at a right angle to the nozzle axis. When the nozzle reflex releases its contents into the after body, shockwaves form. Body heat transfer rate and wall pressure measurements are utilized to verify the CFD model. Because the width of the experimental exit is so much greater than its height, the whole flow is mapped onto just those two dimensions. The exhaust flow enters at a speed of 1.66 m/s. The cowl wall always faces the rear of the vehicle while looking upward. A wedge follows, producing a shockwave that reflects off the trailing body.

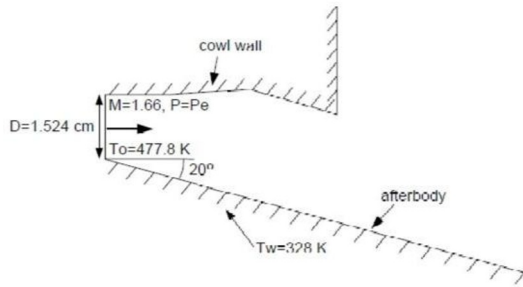

Fig.1. 20-Degree After load.

3.1 Model Analysis

In any kind of CFD simulation, the geometry specification is very important. The physical boundaries that contain the fluid as accurately as possible, which is especially crucial for engineering problems. Any inaccuracy in the boundary surface of the geometry structure may give erroneous results. The grid generation and the geometric design of our structure take a month or longer to perform.

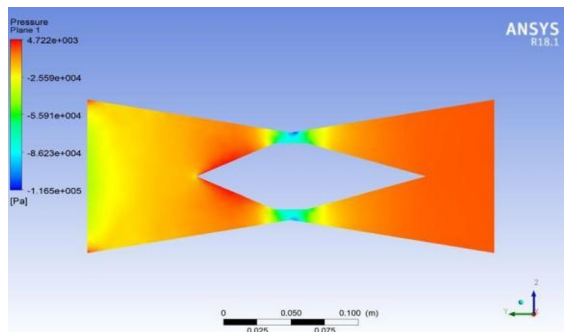

Fig.2. Pressure contours 18 degrees after the body.

The degree of geometry is tested using a two-dimensional grid. The CFD mesh is entirely made out of the quadrilateral cells for the angle of 20-degree geometry.

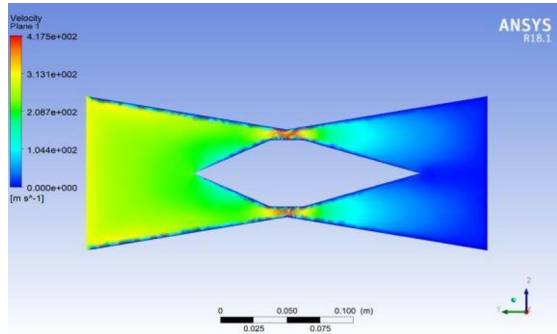

Fig.3. Velocity contours 18 degrees after the body.

The fluid for the supersonic variable contour plots in two dimensions for the various flow variables. The static pressure, static temperature, and Mach number will determine the flow case.

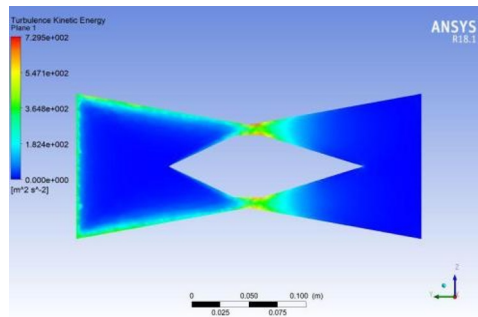

Fig.4. Turbulence kinetic energy on 18-Degree after body.

The physical system that involves fluid flow within definite boundaries is designed in the CFD model by setting the mathematical equation, usually in the differential computation method.

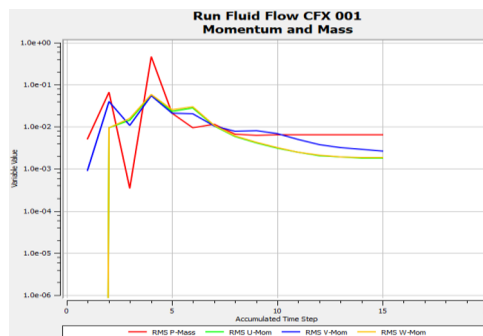

Fig.5. Momentum and mass variation in 18-Degree after body.

The analysis starts with a rough mesh in Gambit, and the first results from this step are not very close to the analytical values. The mesh model denser around 1000000 elements in

order to get a more precise value. The flow change parameters, such as the Mach number, pressure, and temperature, can be obtained by observing and visualizing the above four mesh diagrams [8–10].

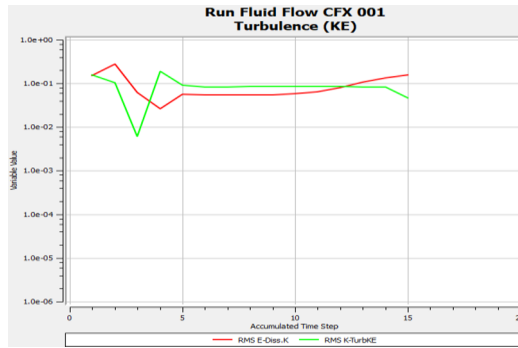

Fig.6. Turbulence variation in the 18-Degree after body.

On observing the final model, the four-step model value is almost close to our calculated theoretical value. From this, conclude that the most accurate result can be achieved. The thrust is provided in a turbojet engine from the takeoff within Mach 3 or 4. The analysis will also help to prove that the result is close to the concert with the small difference in the values.

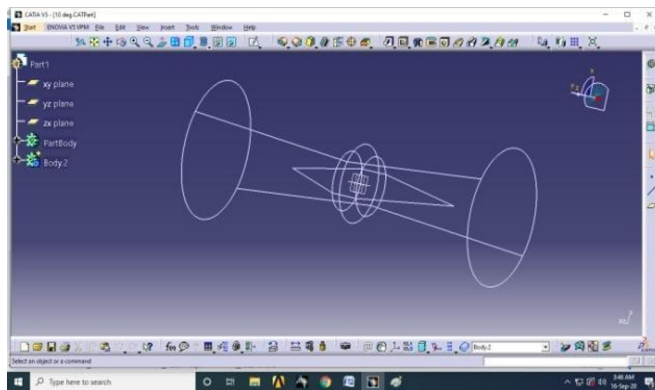

Fig.7. Wire frame view model of 18 degree.

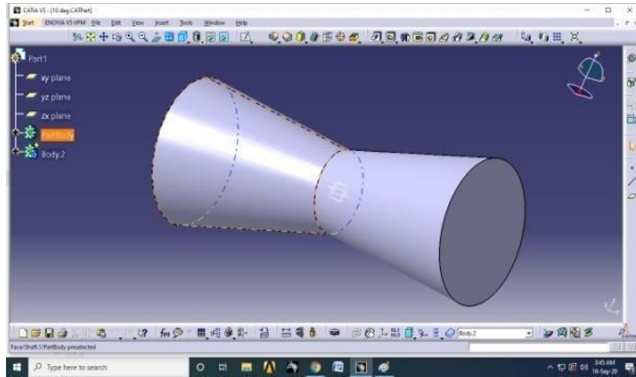

Fig.8. Isometric model of 18 degree.

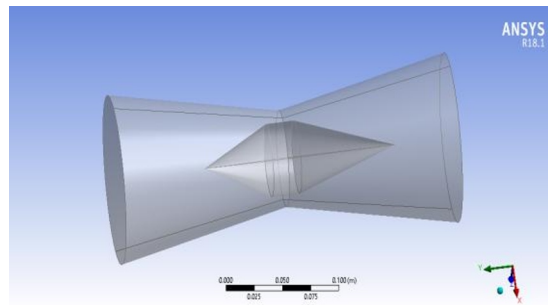

Fig.9. CFD model of 18 degrees.

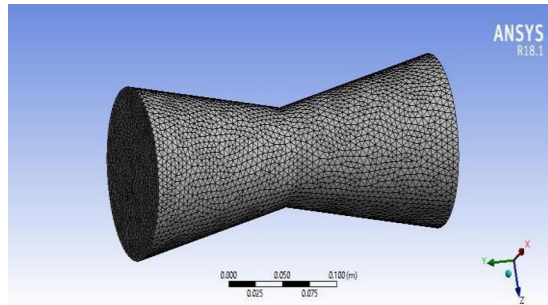

Fig.10. CFD and mesh model of 18 degrees.

The results show that the 15° nozzle works better for flow expansion and thrust than the 10° and 18° nozzles.

4 Conclusion

The supersonic nozzles under different divergent angles (5, 10, and 15 deg) are determined by the 2D axis symmetric type, which resolves governing equations by CV methods. Distinctions in various parameters like static pressure, velocity, temperature, and turbulence intensity are studied in CATIA v5r20. The singularities of oblique shock are pictured, and

note down that at which 18 degrees of divergent angle is totally removed from the nozzle. The focus of this study is to identify the optimal diverging angle. The angles that were looked at (10°, 15°, and 18°). The best divergent angle has also been made, such as velocity, pressure distribution, and estimated thrust improvements.

References

1. R.Varun, T.Sundararajan, R. Usha, K. Srinivasan, Interaction between particle-laden under expanded twin supersonic jets. Proc. Inst. Mech. Eng. Part G: J. Aerosp. Eng. **224**, 1005 (2010)
2. N. Pardhasaradhi, V. Ranjith Kumar, Y.V.H. Rao, Flow analysis of rocket nozzle using computational fluid dynamics. Int. J. Eng. Res. Appl. **2**(5), 1226–1235 (2012)
3. B. Ganapathisubramani, N.T. Clemens, D.S. Dolling, Effect of upstream boundary layer on shock-induced separation. J. Fluid Mech. **585**, 369–394 (2007)
4. J.P. Dussage, P. Dupont, J.F. Debiève, Unsteadiness in shock wave boundary layer interactions with separation. Aerosp. Sci. Technol. **10**(2), 85–91 (2006)
5. V. Sakthimurugan, D. Yuvarajan, S. Ganesan, V.J. Upadhye, A. Gill, N. Kailiappan, Investigation on influence of acetylene enrichment in diesel engines operating with microalgae–waste plastic oil–heptane fuel mixture. Energy Sci. Eng. (2025)
6. S.M. Veeraraghavan, L. G., G. Subbiah, B. N., V.J. Upadhye, Y. Devarajan, L. Bareja, Hydrogen-assisted exhaust gas recirculation in Cascabela Thevetia biodiesel-fuelled diesel engines. Case Stud. Therm. Eng. 106244 (2025)
7. J. Kumaraswamy, C.S. Ramakrishna, S. Ramasubramanian, R. Mishra, D.T. Sakhare, K. Karthik, S. Baskar, K.K. Pandey, Design and analysis of gudgeon pin to minimize stress concentration by selecting different material through FEA. In: Conf. Innovative Product Design and Intelligent Manufacturing System, Springer, Singapore, pp. 339–352 (2023)
8. T. Hai, I. Omar, A.A. Alizadeh, N. Varshney, S. Dixit, A.J. Sultan, N.S. Singh, Optimization of nano-finned enclosure-shaped latent heat thermal energy storage units using CFD, RSM and enhanced hill climbing algorithm. Sci. Rep. **15**, 12486 (2025)
9. S. I. S. Mohammad, A. Vasudevan, K. D. V. Prasad, I. R. Ali, A. Kumar, A. Kulshreshta, and M. Sina, “Evaluation of diesel engine performance and emissions using biodiesel from waste oils synthesized with Fe₃O₄–SiO₂ heterogeneous nano catalyst,” *Heliyon*, **11** (2025).
10. B. Ellappan, V. R. Madhavan, and M. E. H. Attia, “Performance study of a solar still desalination system coupled with solar air heater,” *Desalin. Water Treat.*, **283**, 109–117 (2023).
11. K. Logesh, P. Hariharasakthisudhan, R. J. Bright, S. Kannan, V. Khalkar, and N. Sundaraiah, “Quasi-static compression behavior and crashworthiness of GLARE laminate conical frustum with progressive circular and square cut-outs,” *Polym. Compos.*, **44**, 3685–3697 (2023).